

**Precision
Structural
Engineering, Inc.**

STRUCTURAL ENGINEERING CALCULATIONS

PROJECT: Stainless Cable & Railing – Fascia Mount

PROJECT LOCATION: Washington

PSE PROJECT NUMBER: Stainless Cable & Railing
216-1 Railing

DATE: January 23, 2017

BY: Nabil Taha, Ph.D., P.E.



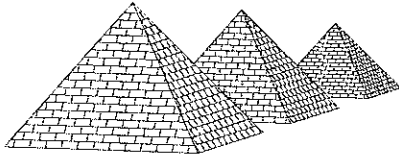
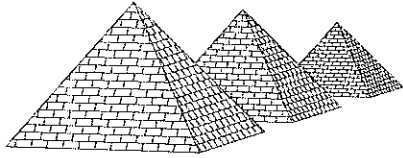

Table of Contents:

| Subject: | Page: |
|------------------------------------|--------------|
| 1- References / Software: | 10-19 |
| 2- Design Criteria: | 100-199 |
| 3- Fascia Mount Analysis & Design: | 1,000-1,999 |



References:

1- Literature:

- a. 2015 International Building Code (IBC)
- b. Aluminum Design Manual ADMI-15, The Aluminum Association.
- c. National Design Specifications for Wood Construction, 2015 Edition

2- Software:

- a. RISA 3D Version 14.0.1
RISA Technologies,
26212 Dimension Dr. Suite 200

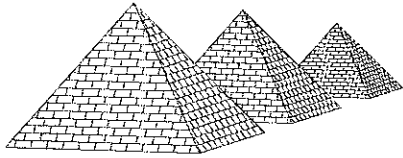

Design Criteria:

- 1- Location: Washington & California
- 2- Live Load on Handrail & guards:
- a. Uniform Distributed load 50 p/f
 - b. Single Concentrated load 200 lbs

**Other criteria assumed as stated in design calculations.

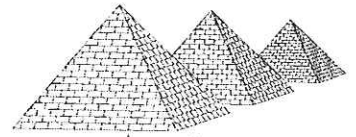

PROJECT NO. Stainless 216-1 SHEET _____ OF _____

PROJECT NAME _____ DESIGNED BY AF DATE 1/19/17

SUBJECT Fascia Mount CHECKED BY NT DATE 1-26-17

Conclusion

Fascia mount with bracket

* Bracket size, 316 SS, minimum size
[4.01" * 6.75" * 0.39"]

* Minimum Anchor bolt or lag screw size:

1- 4 - $\frac{3}{8}$ " ϕ w/min 4" Embed, Red head ITW wedge

2- 4 - $\frac{3}{8}$ " ϕ w/min 4" Embed, Red head LDT

3- 4 - $\frac{3}{8}$ " ϕ lag screw w/min 5" Embed.

Fascia Mount with no bracket

1- 2 - $\frac{1}{2}$ " ϕ w/min 4" Embed, 7" apart

2- 2 - $\frac{1}{2}$ " ϕ lag screw w/min 6" Embed, 7" apart

3- 2 - $\frac{1}{2}$ " ϕ thru-bolt, Hex bolt

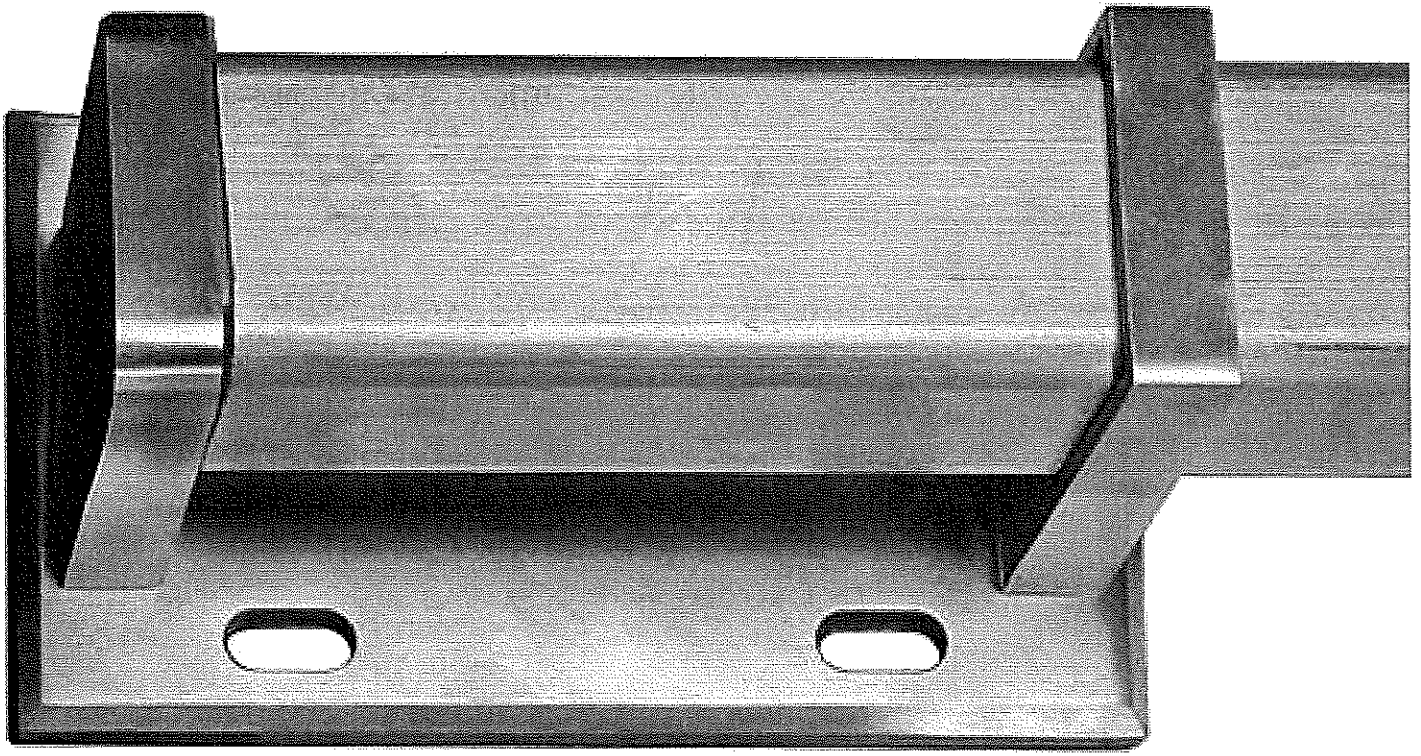

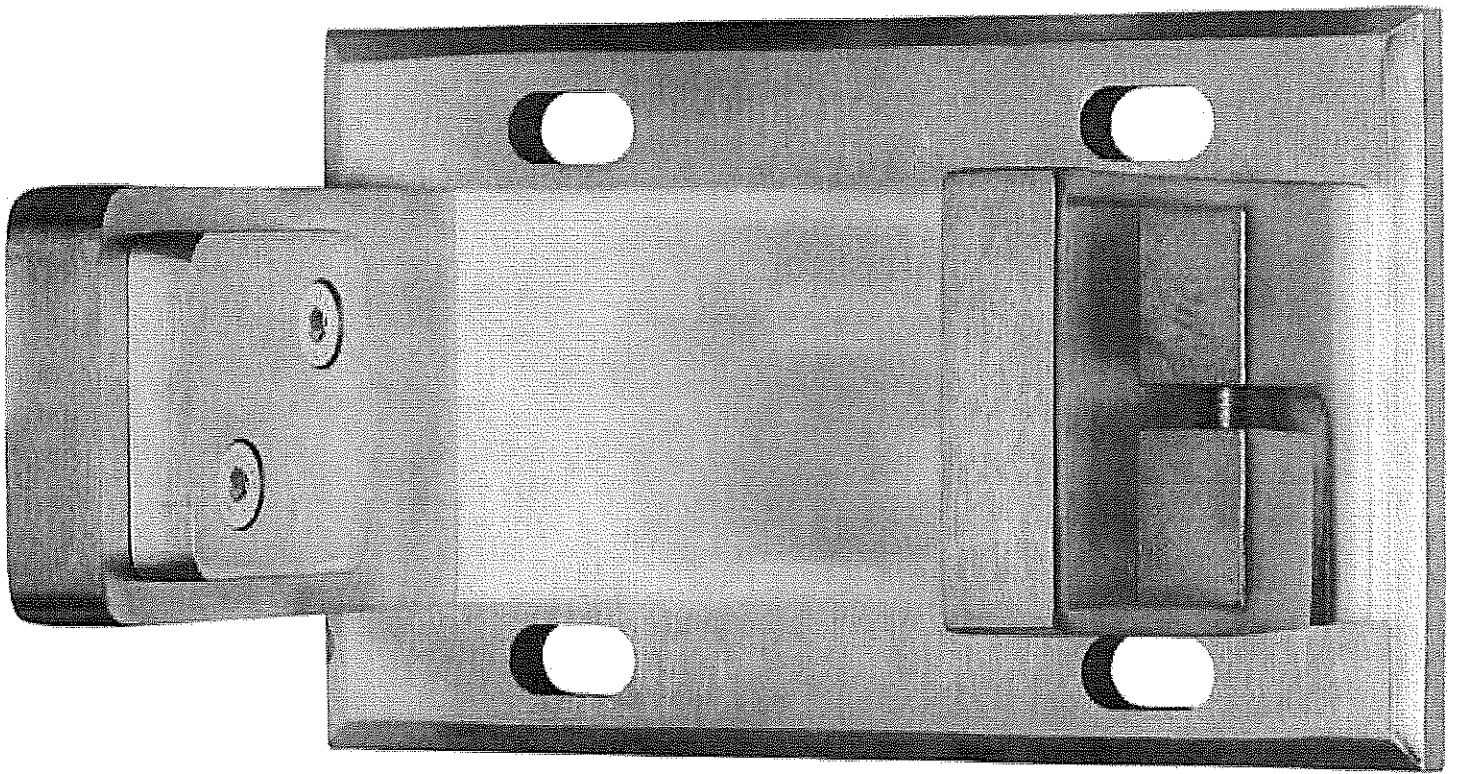

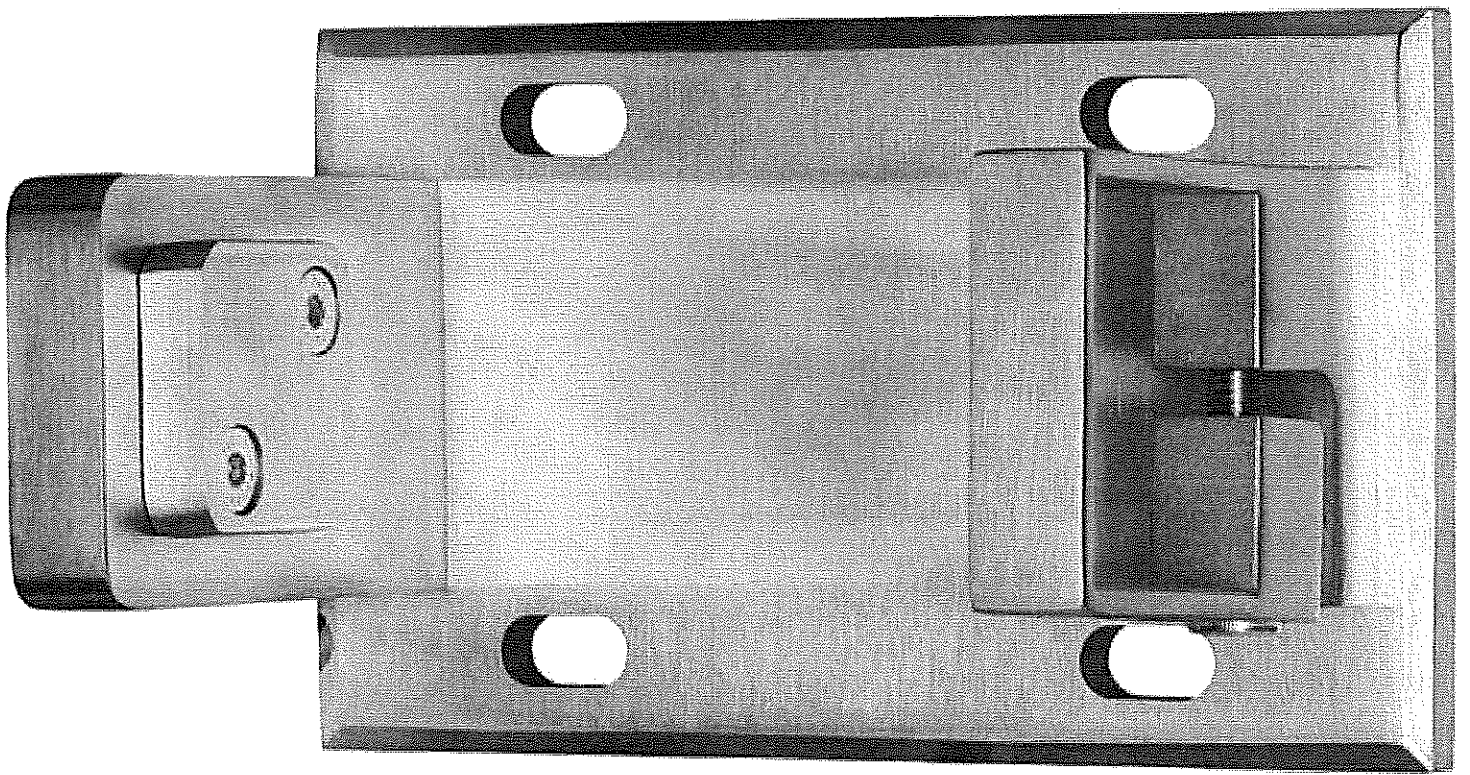

**Terminal
Post Holder**

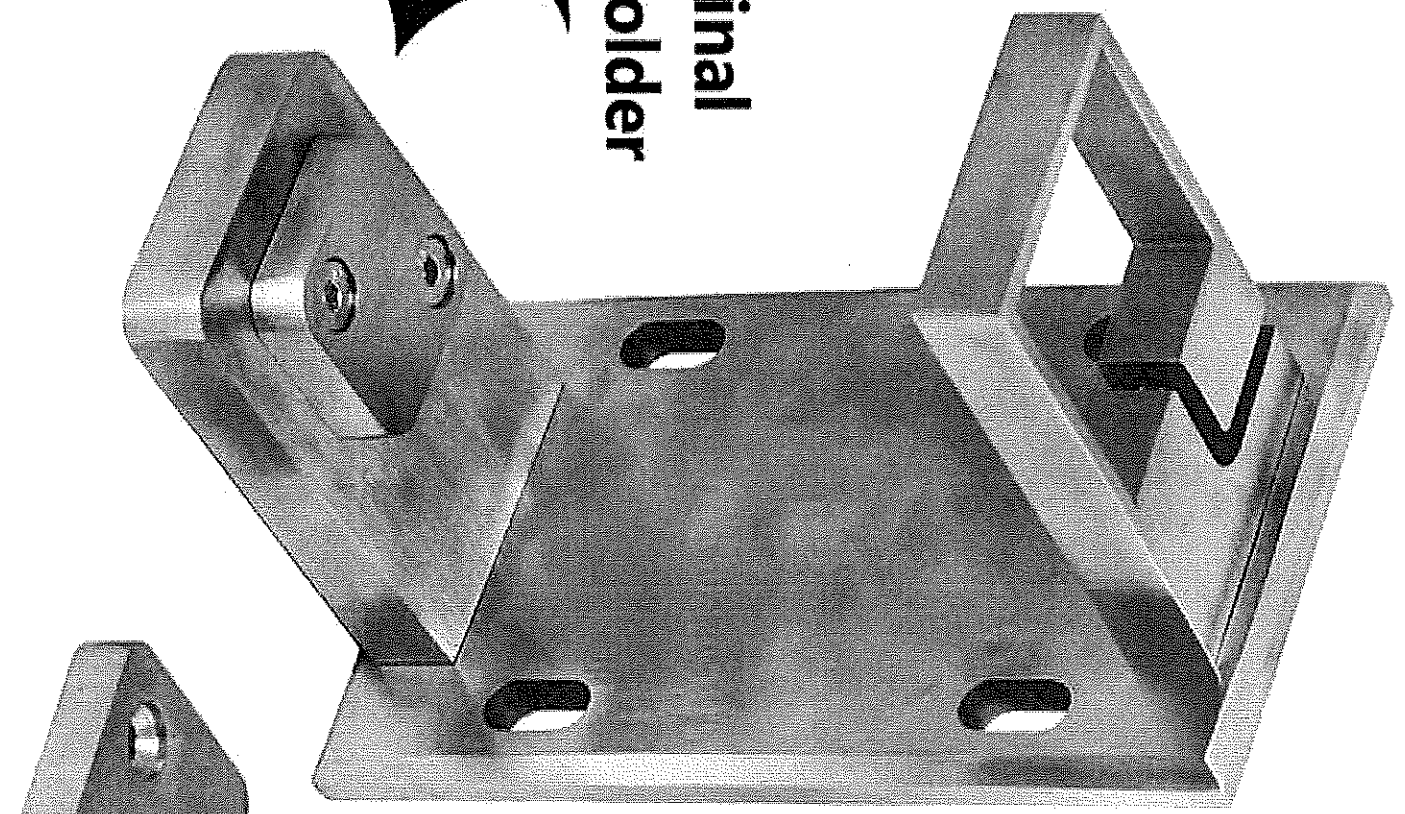

**Intermediate
Post Holder**

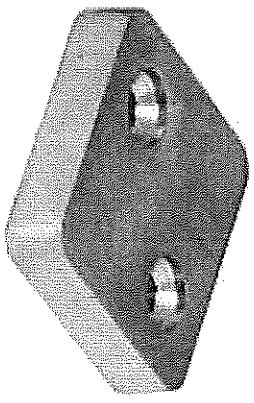

1263.65
 1193.8
 1117.6
 1041.4
 965.2
 889.0
 812.8
 736.6
 660.4
 584.2
 508.0
 431.8
 355.6
 279.4

13x ϕ 5.25 THRU ALL
 L ϕ 15.0 ∇ 10.0

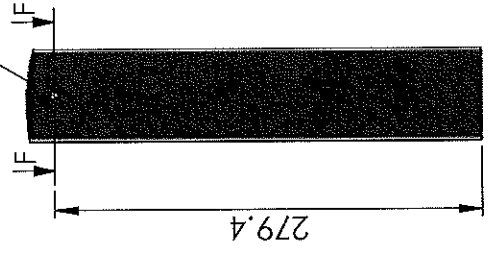

DETAIL D
 SCALE 2:9

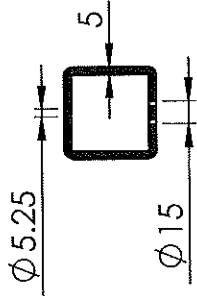

SECTION F-F
 SCALE 2:9

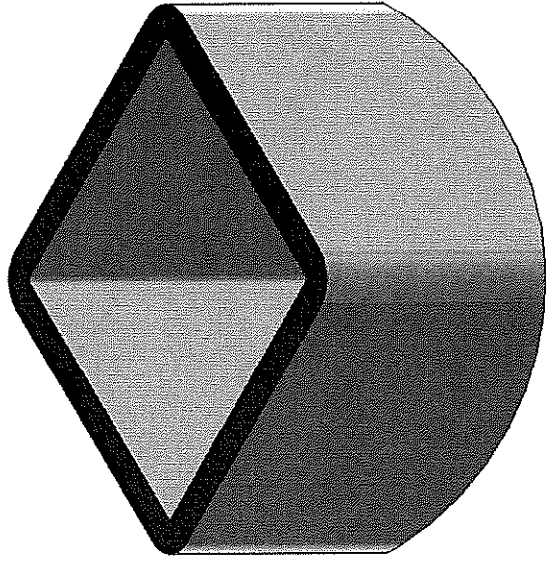

- NOTES:** UNLESS OTHERWISE SPECIFIED
1. DIMENSIONS ARE IN MM.
 2. MACHINED SURFACES TO BE 63 μ IN MAX.
 3. DO NOT SCALE DRAWING.
 4. PART TO BE FREE OF BURRS AND SHARP EDGES.
 5. ALL MATERIAL TO BE CLEAN, DEGREASED AND FREE OF ALL IMPURITIES.
 6. ANY CHANGE MUST BE AUTHORIZED BY AN SC&R ENGINEER.

MATERIAL TYPE: 316 SS
 VENDOR ID:

| REV | DATE | DESCRIPTION OF CHANGE | ECN | BY. | APPR |
|---|------|---|-----|--|------|
| REVISIONS | | | | | |
| | | TOLERANCES XX+0.1 UNLESS OTHERWISE SPECIFIED XX-0.05 ANGULAR 0.5* FRACTIONAL 1/32 | | TITLE: Square Tube Fascia-mount 42" Swageless Terminal Post | |
| DRAWN BY: PA | | DATE: 12.01.13 | | DRG NO. 06-001-01x49.75-D3F | |
| | | PROJECT: ** | | SHEET 1 OF 1 | |
| THIS DRAWING IS THE PROPERTY OF STAINLESS CABLE & RAILING AND IS PROTECTED UNDER COPYRIGHT LAW AS AN UNPUBLISHED WORK. IT MAY NOT BE PUBLISHED, COPIED OR REPRODUCED WITHOUT EXPRESS WRITTEN PERMISSION FROM SC&R | | | | | |

06-001-01x49.75-D2F
ON DMD

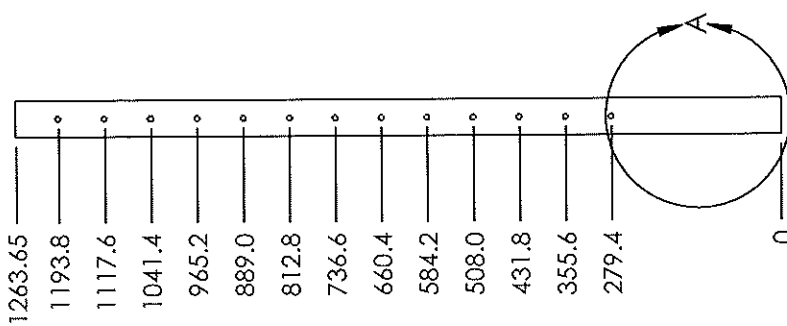

13X Ø 8.5 THRU ALL

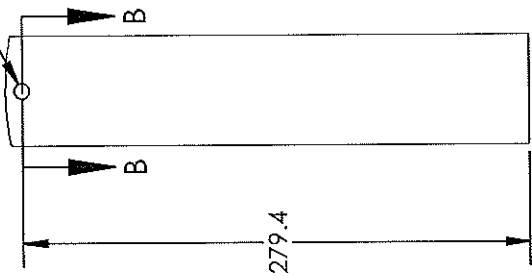

DETAIL A
SCALE 1:4

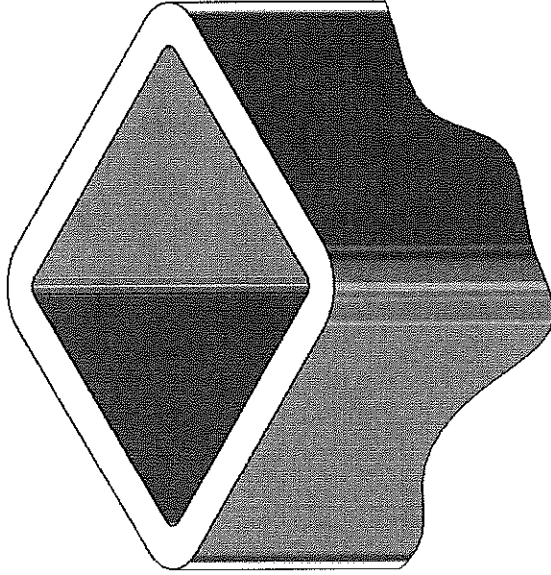
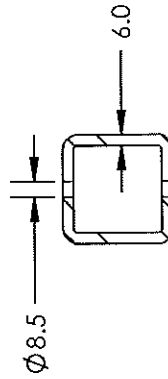

SECTION B-B
SCALE 1:4

| DATE | NAME | DATE | REV |
|--|------|--|---------------------|
| | GM | | |
| DRAWN | | TITLE: Square Tube Fascia-Mount 42" Tensioner Terminal Post | |
| CHECKED | | SIZE | DWG. NO. |
| ENG APPR. | | A | 06-001-01x49.75-D2F |
| MFG APPR. | | SCALE: 1:20 WEIGHT: SHEET 1 OF 1 | |
| Q.A. | | COMMENTS: | |
| UNLESS OTHERWISE SPECIFIED: DIMENSIONS ARE IN Millimeters | | TOLERANCES: X = 0.1 XX = 0.1 XXX = 0.01 XXXX = 0.005 | |
| INTERPRET GEOMETRIC TOLERANCING PER: | | MATERIAL: 316 SS | |
| FINISH | | USED ON | |
| DO NOT SCALE DRAWING | | APPLICATION | |
| NEXT ASSY | | 5 | |
| APPLICATION | | 4 | |
| DO NOT SCALE DRAWING | | 3 | |
| COMMENTS: | | 2 | |
| Q.A. | | 1 | |

PROPRIETARY AND CONFIDENTIAL
THE INFORMATION CONTAINED IN THIS DRAWING IS THE SOLE PROPERTY OF STAINLESS CABLE & RAILING, INC. ANY REPRODUCTION IN PART OR AS A WHOLE WITHOUT THE WRITTEN PERMISSION OF STAINLESS CABLE & RAILING, INC. IS PROHIBITED.

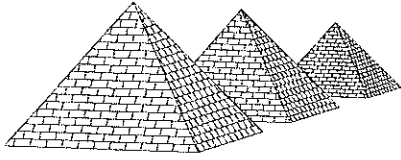

**Precision
Structural
Engineering, Inc.**

FISCIA MOUNT ANALYSIS & DESIGN:

Pages 1,000 - 1,999



PROJECT NO. Stainless Cable 216-1 SHEET 1000 OF _____
PROJECT NAME _____ DESIGNED BY AF DATE _____
SUBJECT Fascia mount CHECKED BY _____ DATE _____

fascia mount bracket design

Shear = 250 lb

M = 875 lb-ft

Per page (1001)

use [4.01" x 6.75" x 0.39" SS316]

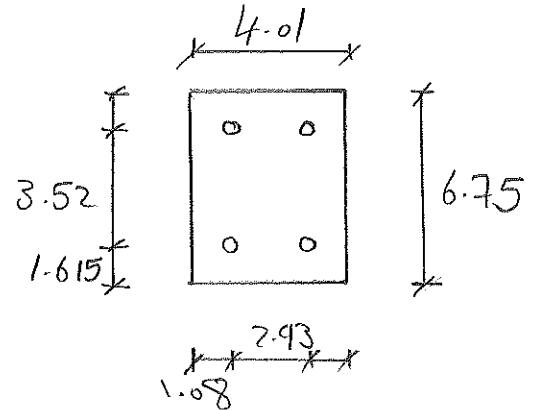

STEEL COLUMN BASE PLATE ANALYSIS

Per AISC 9th Edition Manual (ASD) and "Design of Welded Structures" (O. Blodgett)
For Axial Load with or without Moment

| | | | |
|-------------|--|-------------|----------|
| Job Name: | | Subject: | |
| Job Number: | | Originator: | Checker: |

Input Data:

Column Size:

Select: W4x13

Column Loadings:

| | | |
|------------------------|------|----------|
| Axial Load, P(total) = | 0.00 | kips |
| Axial Load, P(DL) = | 0.00 | kips |
| Shear Load, V(total) = | 0.25 | kips |
| Moment @ Base, M = | 0.90 | ft.-kips |

Column Properties:

| | | |
|------|-------|-------|
| A = | 3.83 | in.^2 |
| d = | 4.160 | in. |
| tw = | 0.280 | in. |
| bf = | 4.060 | in. |
| tf = | 0.345 | in. |

Design Parameters:

| | | |
|--------------------------|-------|-------|
| Base Plate Length, N = | 6.750 | in. |
| Base Plate Width, B = | 4.010 | in. |
| Plate Yield Stress, Fy = | 30.00 | ksi |
| Concrete Strength, f'c = | 2.500 | ksi. |
| Bearing Area, A2 = | 24.00 | in.^2 |
| Shear Coef., C = | 1.85 | |
| Coef. of Friction, μ = | 0.70 | |

Anchor Bolt/Rod Data:

| | | |
|--------------------------|------------|-----|
| Total No. of Bolts, Nb = | 4 | |
| Bolt Diameter, db = | 0.375 | in. |
| Anchor Bolt Material = | F1554 (36) | |
| Bolt Edge Dist., ED1 = | 1.600 | in. |
| Bolt Edge Dist., ED2 = | 1.080 | in. |

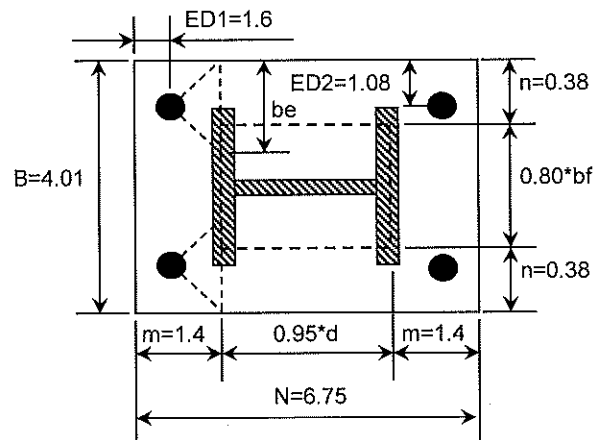

Plan

Results:

Eccentricity, Bearing Length, and Bearing Pressures:

| | | |
|-------------------|----------|-----|
| Eccentricity, e = | Infinity | in. |
| Length, Xc = | 1.907 | in. |
| Fp = | 0.824 | ksi |
| fp(max) = | 0.626 | ksi |
| fp(min) = | 0.000 | ksi |

Fp >= fp(max), O.K.

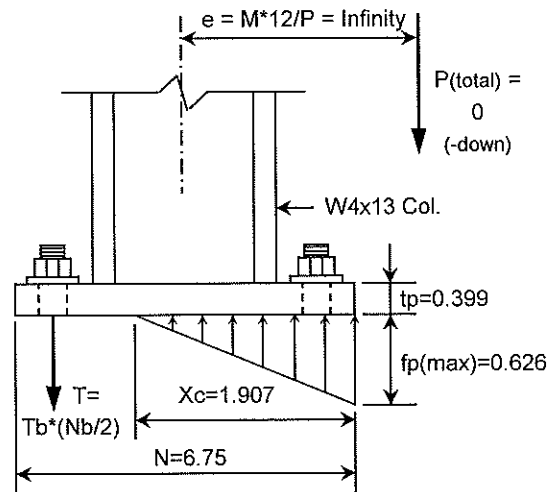

Elevation

Anchor Bolt/Rod Tension and Shear:

| | | |
|------|-------|--------|
| Ft = | 19.10 | ksi |
| Ta = | 2.11 | k/bolt |
| Tb = | 1.20 | k/bolt |

Ta >= Tb, O.K.

| | | |
|------------|------|------------------------|
| Fv = | 9.90 | ksi |
| Va = | 1.09 | k/bolt |
| V(bolts) = | 0.25 | = V(total)-1/2*μ*P(DL) |
| Vb = | 0.06 | k/bolt |

Va >= Vb, O.K.

(Interaction) S.R. = 0.673 = $T_b / (T_a + (C \cdot V_b) / V_a)$
S.R. <= 1.0, O.K.

Base Plate Thickness:

tp(req'd) = 0.399 in.

Suggested plate thickness for rigidity:
tp(min) = 0.350 in. tp(min) >= max. of m/4 or n/4

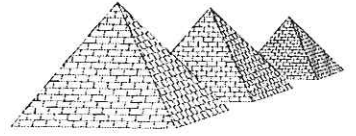

PROJECT NO. Stainless Cable 216-1 SHEET 1002 OF _____

PROJECT NAME _____ DESIGNED BY AF DATE _____

SUBJECT Fiscia Mount CHECKED BY NT DATE 1-26-17

* Connection design

post height = 42"

applied load = 200 lb (Concentrated)

$$M_{@base} = 200(1b) \times 42(in) = 8400 \text{ lb}\cdot\text{in} \quad (1)$$

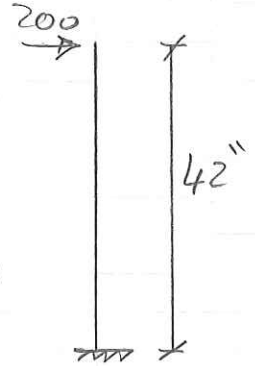

applied load = 50 lb/ft (Distributed)

spacing between posts (max) = 5 ft

$$M_{@base} = 50(1b/ft) \times 5(ft) \times 42(in) = 10,500 \text{ lb}\cdot\text{in} \quad (2)$$

From (1), (2)

$$\begin{aligned} \text{Design moment} &= 10,500 \text{ lb}\cdot\text{in} \\ &= 875 \text{ lb}\cdot\text{ft} \end{aligned}$$



PROJECT NO. Stainless Cable 216-1 SHEET 1003 OF _____

PROJECT NAME _____ DESIGNED BY AF DATE _____

SUBJECT Fascia Mount CHECKED BY _____ DATE _____

Fascia Mount to Concrete

Applied moment = 875 lb-ft

Bolt spacing = 3.52"

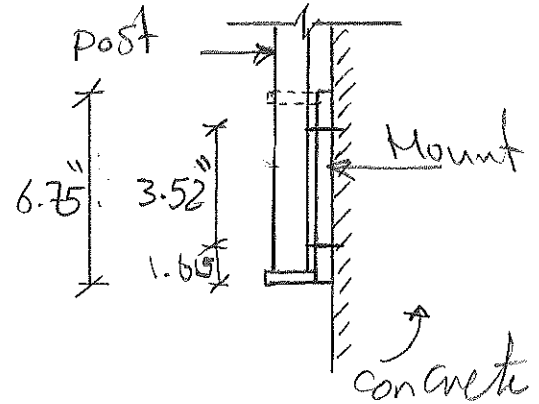

Tension induced in bolts = $\frac{M}{d}$

M = applied moment = 875 lb-ft

d = spacing between Tension and Compression lines

= spacing between bolts rows + edge distance

= 3.52 (in) + 1.615 (in)

= 5.135 in

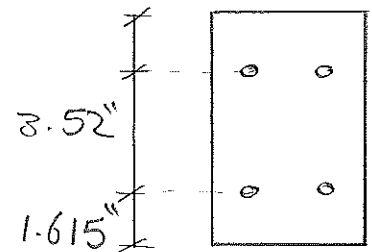

°° Tension = $\frac{875(16 \cdot ft)}{5.135/12} = 2044 \text{ lb}$



PROJECT NO. Stainless cable 216-1 SHEET 1004 OF _____
PROJECT NAME _____ DESIGNED BY AF DATE _____
SUBJECT Fascia Mount CHECKED BY _____ DATE _____

Fascia mount to 2500 psi Concrete

use ITW Red head Trubolt wedge

Anchor strength is based on ESR-2427
Page 1013-1029

$f'_c = 2500$ psi, min. Embed = 4"

bolt spacing = 3.52"

min. Edge distance = 2.5"

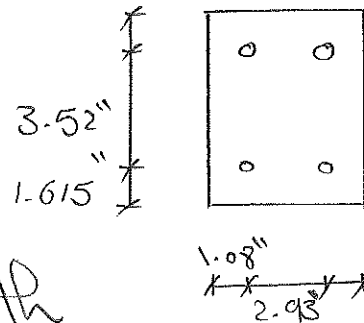

* Check Concrete break out strength

ACI 318-14

$$N_{cbg} = \frac{A_{Nc}}{A_{Nco}} \cdot \psi_{ec,N} \psi_{ed,N} \psi_{c,N} \psi_{cp,N} N_b \quad (17.4.2.1.b)$$

$$\begin{aligned} A_{Nc} &= (C_1 + S_1 + 1.5 h_{ef}) (2 \times 1.5 h_{ef} + S_2) \\ &= (2.5" + 3.52" + 1.5 \times 4) (2 \times 1.5 \times 4 + 2.93) \\ &= 179.45 \text{ in}^2 \end{aligned}$$

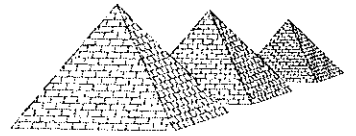

PROJECT NO. Stainless Cable 216-1 SHEET 1005 OF _____

PROJECT NAME _____ DESIGNED BY AF DATE _____

SUBJECT Fascia mount CHECKED BY _____ DATE _____

$$A_{NCO} = 9 \overline{h_{ef}}^2 = 9 \times 4^2 = 144 \text{ in}^2$$

$$\psi_{CPN} = \max \left(\frac{1.5}{4''} \text{ or } 1.5 \times \frac{4''}{4''} \right) = 1.5 > 1.0$$

Use $\psi_{CPN} = 1.0$

$$N_b = K_c \lambda_a \sqrt{f_c} \overline{h_{ef}}^{1.5} \quad (17.4.2.2a)$$

$$K_c = 24$$

$$\lambda_a = 1.0$$

$$N_b = 24 \sqrt{2500} \times 4^{1.5} = 9600 \text{ lb}$$

$$N_{cbg} = \frac{179.45}{144} \times 1.0 \times 1.0 \times 1.0 \times 9600 (\text{lb}) = 11963 \text{ lb}$$

∴ Concrete breakout strength of '4' bolts = 11963 lb

Bolt Tensile strength = 4200 lb

Tensile strength of 2 bolts = $2 \times 4200 = 8400 \text{ lb}$

Concrete breakout strength = 11963 lb

∴ Bolts Control



PROJECT NO. Stainless cable 216-1 SHEET 1006 OF _____
PROJECT NAME _____ DESIGNED BY AF DATE _____
SUBJECT Fascia Mount CHECKED BY _____ DATE _____

$$\phi_o \text{ Allowable Tension load} = 0.65 * \frac{8400 \text{ (lb)}}{1.6}$$
$$T_s = 3,412 \text{ lb}$$

* Check shear strength - Concrete breakout strength in shear

$$V_{cb} = \frac{A_{vc}}{A_{vc0}} \phi_{ec,v} \phi_{ed,v} \phi_{cv} \phi_{hv} V_b \quad (17.5.2.1b)$$

$$A_{vc} = 1.5 C_{a1} (1.5 * 2 C_{a1} + S_1)$$

$$= 1.5 * 3 (1.5 * 2 * 2.5 + 3.52) = 49.59 \text{ in}^2$$

$$A_{vc0} = 4.5 C_{a1}^2, \quad C_{a1} = \text{edge distance}$$

$$= 4.5 * 2.5^2 = 28.125$$

$$\phi_{cv} = 1.0 \quad \text{Cracked concrete}$$

$$\phi_{hv} = \sqrt{1.5 (C_{a1}/h_a)} = 1.5 * \frac{2.5}{3} = 1.25$$

h = member thickness, Assume $h_a = 3$



PROJECT NO. stainless cable 216-1 SHEET 1007 OF _____

PROJECT NAME _____ DESIGNED BY AF DATE _____

SUBJECT fascia Mount CHECKED BY _____ DATE _____

$$V_b = \left[7 \left(\frac{e_c}{d_c} \right)^{0.2} \sqrt{d_c} \right] * \lambda_a \sqrt{f_c'} (C_{a_1})^{1.5} \quad (17.5.2.2a)$$

$$= \left[7 * \left(\frac{4}{3/8} \right)^{0.2} * \sqrt{3/8} \right] * 1.0 * \sqrt{2500} * 3^{1.5}$$

$$= 1788 \text{ (lb)}$$

$$V_{cb} = \frac{49.59}{78.125} * 1.25 * 1788 = 3940 \text{ lb}$$

bolts shear strength = 1830 (lb) * 2 = 3600 lb

ESR-2427 Table-4 \uparrow

no. of bolts \downarrow

$$\begin{aligned} \text{Allowable shear strength} &= \phi V_n / 1.6 \\ &= 0.7 * 1788 \text{ (lb)} / 1.6 \\ &= 782.25 \text{ lb} \end{aligned}$$

$$\text{Applied shear load} = \frac{50 \text{ lb/ft} * 5}{782.25} = 0.32 > 0.2$$

∴ use shear-tension interaction



PROJECT NO. Stainless Cable 216-1 SHEET 1008 OF _____
PROJECT NAME _____ DESIGNED BY AF DATE _____
SUBJECT Fascia Mount CHECKED BY _____ DATE _____

$$\text{Tension load: } \frac{\text{Applied Tension}}{\text{Allowable Tension}}$$

utility

$$= \frac{2044 \text{ (lb)}}{3412 \text{ (lb)}} = 0.599 > 0.2$$

$$\therefore \frac{N_{u3}}{\phi N_n} + \frac{V_{u3}}{\phi V_n} > 1.2$$

$$0.599 + 0.32 = 0.919 < 1.2 \quad (\text{OK})$$

\therefore use $\left[\begin{array}{l} 4 - \frac{3}{8} \text{ } \phi \text{ Red head ITW or LDT} \\ \text{w/min. 4" Embed. } \sum 3 \text{ " edge} \\ \text{distance.} \\ f'_c \neq 2500 \text{ PSI, Concrete member} \\ \text{thickness } \neq 3 \text{ "} \end{array} \right]$



PROJECT NO. Stainless Cable 716-1 SHEET 1009 OF _____

PROJECT NAME _____ DESIGNED BY AF DATE _____

SUBJECT Fascia mount CHECKED BY _____ DATE _____

Fascia mount to wood

$$\text{wood specific weight} = 0.43$$

$$\text{Tension load} = 2044 \text{ lb}$$

$$\% \text{ Tension / bolt} = \frac{2044 \text{ lb}}{2} = 1022 \text{ lb}$$

$$\frac{3}{8} \text{ } \phi \text{ lag screw withdrawal capacity} = 243 \text{ lb/in} \quad (\text{page 1030})$$

$$\text{min embed} = \frac{1022 \text{ lb}}{243 \text{ (lb/in)}} = 4.2 \text{ in}$$

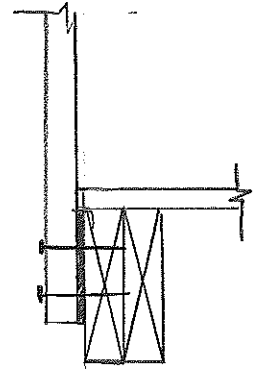

check shear

$$\text{Shear load} = 250 \text{ lb}$$

$$\frac{3}{8} \text{ } \phi \text{ lag screw shear capacity} = 150 \text{ lb} \quad (\text{page 1031})$$

$$\% \text{ total shear capacity of 4 screws} = 4 \times 150 = 600 \text{ lb}$$

$> 250 \text{ lb}$
(OK)

use [4 - $\frac{3}{8}$ " ϕ lag screw w/ min. 5" Embed]



PROJECT NO. stainless cable 216-1 SHEET 1010 OF _____

PROJECT NAME _____ DESIGNED BY HF DATE _____

SUBJECT Fabric mount CHECKED BY _____ DATE _____

post is directly attached with no bracket

* with concrete

$\frac{3}{8}$ ϕ red head ITW

Allowable Tension load / bolt =

$$0.65 \times \frac{42000 \text{ lb}}{1.6}$$

$$= 1706 \text{ lb}$$

$$\text{Applied Tension} = \frac{M}{d}$$

$$\# \text{ of bolts to resist} = 1.0$$

$$\frac{M}{d} \neq 1706 \text{ lb}$$

$$\frac{875 \text{ (lb/ft)} \times 12}{d} = 1706 \text{ lb}$$

$$d = 6.15$$

∴ spacing between anchors is 7"

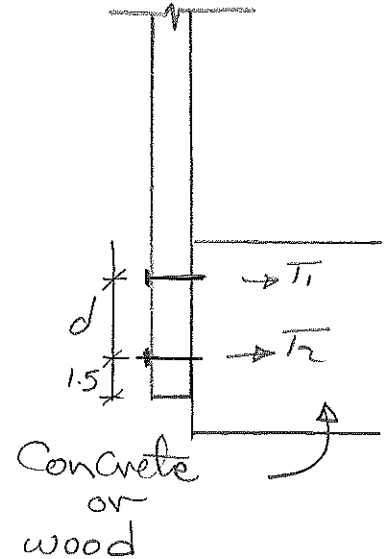

Precision Structural Engineering, Inc.
250 Main Street, Suite A • Klamath Falls, OR 97601
Tel (541) 850-6300 • FAX (541) 850-6233

Medford Office
836 Mason Way (off Sage Road) • Medford, OR 97501
Tel (541) 858-8500

www.structure1.com • Email: info@structure1.com

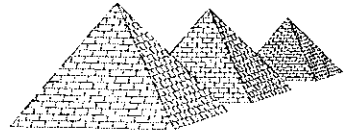

PROJECT NO. Stainless Cable 216-1 SHEET 1 of 1 OF _____
PROJECT NAME _____ DESIGNED BY AF DATE _____
SUBJECT Fascia Mount CHECKED BY _____ DATE _____

o° use [2 - $\frac{1}{2}$ " red head ITW or LDT
7" apart w/min 4" Embed.
post to extend 1.5" below bottom anchor
fc' \geq 2500 psi, Concrete member
thickness \geq 3"]



PROJECT NO. Stainless cable 216-1 SHEET 1012 OF _____

PROJECT NAME _____ DESIGNED BY AF DATE _____

SUBJECT Fascia Mount CHECKED BY _____ DATE _____

* with wood

$d = 7''$ (spacing between lag screws)

M@ bottom of post = 875 lb-ft

Resisting moment = $T_1 \times 1.5 + T_2 \times 8.5$

$$T_1 = T_2 \times \frac{1.5}{8.5}$$

$$\circ \circ \text{ Resisting moment} = 1.5 \times \frac{1.5}{8.5} \times T_2 + 8.5 T_2$$

$$= 8.76 T_1 \text{ (in. load)}$$

for equilibrium = $M = \text{resisting moment}$

$$875 \text{ (lb-ft)} \times 12 = 8.76 T_1$$

$$\circ \circ T_1 = 1198 \text{ lb}$$

$$\circ \circ \text{ Embed. length} = \frac{T}{\text{with drawl capacity}}$$
$$= \frac{1198}{243} = 4.9''$$

$\circ \circ$ use $\left[2 - \frac{1}{2}'' \phi \text{ lag screws, } 7'' \text{ apart w/min } 6'' \text{ Emb.} \right]$

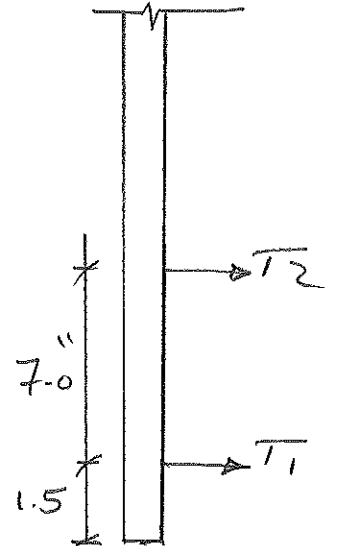

1013



ICC
EVALUATION
SERVICE

In Cooperation with



Most Widely Accepted and Trusted

ICC-ES Report

ESR-2427

ICC-ES | (800) 423-6587 | (562) 699-0543 | www.icc-es.org

Reissued 11/2016
This report is subject to renewal 11/2017.

DIVISION: 03 00 00—CONCRETE

SECTION: 03 16 00—CONCRETE ANCHORS

DIVISION: 05 00 00—METALS

SECTION: 05 05 19—POST-INSTALLED CONCRETE ANCHORS

REPORT HOLDER:

ITW RED HEAD

700 HIGH GROVE BOULEVARD
GLENDALE HEIGHTS, ILLINOIS 60139

EVALUATION SUBJECT:

ITW RED HEAD CARBON STEEL TRUBOLT+ WEDGE ANCHORS, STAINLESS STEEL TRUBOLT+ WEDGE ANCHORS AND CARBON STEEL OVERHEAD TRUBOLT+ WEDGE ANCHORS FOR CRACKED AND UNCRACKED CONCRETE



Look for the trusted marks of Conformity!

"2014 Recipient of Prestigious Western States Seismic Policy Council (WSSPC) Award in Excellence"



A Subsidiary of  INTERNATIONAL CODE COUNCIL

ICC-ES Evaluation Reports are not to be construed as representing aesthetics or any other attributes not specifically addressed, nor are they to be construed as an endorsement of the subject of the report or a recommendation for its use. There is no warranty by ICC Evaluation Service, LLC, express or implied, as to any finding or other matter in this report, or as to any product covered by the report.



ICC-ES Evaluation Report

ESR-2427

Reissued November 2016

This report is subject to renewal November 2017.

www.icc-es.org | (800) 423-6587 | (562) 699-0543

A Subsidiary of the International Code Council®

DIVISION: 03 00 00—CONCRETE
Section: 03 16 00—Concrete Anchors

DIVISION: 05 00 00—METALS
Section: 05 05 19—Post-installed Concrete Anchors

REPORT HOLDER:

ITW RED HEAD
700 HIGH GROVE BOULEVARD
GLENDALE HEIGHTS, ILLINOIS 60139
(800) 848-5611
www.itw-redhead.com
techsupport@itwccna.com

ADDITIONAL LISTEE:

ITW BRANDS
955 NATIONAL PARKWAY, SUITE 95500
SCHAUMBURG, ILLINOIS 60173
(877) 489-2726
www.itwbrands.com

EVALUATION SUBJECT:

ITW RED HEAD CARBON STEEL TRUBOLT+ WEDGE ANCHORS, STAINLESS STEEL TRUBOLT+ WEDGE ANCHORS AND CARBON STEEL OVERHEAD TRUBOLT+ WEDGE ANCHORS FOR CRACKED AND UNCRACKED CONCRETE

1.0 EVALUATION SCOPE

Compliance with the following codes:

- 2015, 2012, 2009, and 2006 *International Building Code*® (IBC)
- 2015, 2012, 2009, and 2006 *International Residential Code*® (IRC)
- 2013 *Abu Dhabi International Building Code* (ADIBC)[†]

[†]The ADIBC is based on the 2009 IBC. 2009 IBC code sections referenced in this report are the same sections in the ADIBC.

Property evaluated:

Structural

2.0 USES

The carbon steel and stainless steel Trubolt+ Wedge Anchors and 3/8-inch-diameter (9.5 mm) carbon steel OVERHEAD Trubolt+ Wedge Anchor are used to resist static, wind, and seismic tension and shear loads (Seismic Design Categories A thru F) in cracked and uncracked

normal-weight and lightweight concrete having a specified compressive strength, f'_c , ranging from 2,500 psi to 8,500 psi (17.2 MPa to 58.6 MPa) [minimum of 24 MPa is required under ADIBC Appendix L, Section 5.1.1].

The carbon steel Trubolt+ Wedge Anchors with diameters of 3/8 inch (9.5 mm), 1/2 inch (12.7 mm) and 5/8-inch (15.9 mm) and the carbon steel OVERHEAD 3/8-inch-diameter (9.5 mm) are used to resist static, wind, and seismic tension and shear loads in cracked and uncracked normal-weight or sand-lightweight concrete over steel deck having a minimum specified compressive strength, f'_c , of 3,000 psi (20.7 MPa) [minimum of 24MPa is required under ADIBC Appendix L, Section 5.1.1].

The Trubolt+ Wedge anchors comply with anchors as described in Section 1901.3 of the 2015 IBC, Section 1909 of the 2012 IBC, and Section 1912 of the 2009 and 2006 IBC. The anchors are alternatives to cast-in-place anchors described in Section 1908 of the 2012 IBC, and Section 1911 of the 2009 and 2006 IBC. The anchors may also be used where an engineered design is submitted in accordance with Section R301.1.3 of the IRC.

3.0 DESCRIPTION

3.1 RED HEAD Carbon Steel Trubolt+ Wedge Anchor:

The RED HEAD Trubolt+ Wedge Anchor is a torque-controlled, wedge-type mechanical expansion anchor, available in 3/8-inch (9.5 mm), 1/2-inch (12.7 mm), 5/8-inch (15.9 mm) and 3/4-inch (19.1 mm) diameters. The Trubolt+ Wedge Anchor consists of a high-strength threaded anchor body, expansion clip, hex nut and washer. The anchor body is cold-formed from low carbon steel materials conforming to AISI 1015 or AISI 1018 with mechanical properties (yield and ultimate strengths) as described in Tables 3 and 4 of this report. The zinc plating on the anchor body complies with ASTM B633 SC1, Type III, with a minimum 0.0002-inch (5 µm) thickness. The expansion clip is fabricated from low carbon steel materials conforming to AISI 1020. The standard hexagonal steel nut conforms to ANSI B18.2.2-65 and the washer conforms to ANSI/ASME B18.22.1 1965 (R1981). The Trubolt+ Wedge anchor body consists of a threaded section throughout the majority of its length and a wedge section at the far end. The expansion clip is formed around the anchor, just above the wedge. The expansion clip consists of a split cylindrical ring with undercutting grooves at the bottom end. During torquing of the anchor, the grooves in the expansion clip are designed to cut into the walls of the concrete hole as the wedge portion of the stud is forced upward against the interior of the clip (U.S. patent nos. 7,744,320 and 7,811,037). The Trubolt+ Wedge anchor is illustrated in Figure 1 of this report.

3.2 RED HEAD Stainless Steel Trubolt+ Wedge Anchor:

The RED HEAD Trubolt+ Wedge Anchor is a torque-controlled, wedge-type mechanical expansion anchor, available in $\frac{1}{2}$ -inch (12.7 mm) and $\frac{5}{8}$ -inch (15.9 mm) diameters. The Trubolt+ Wedge Anchor consists of a high-strength threaded anchor body, expansion clip, hex nut and washer. The anchor body is cold-formed from AISI Type 316 stainless steel materials with mechanical properties (yield and ultimate strengths) as described in Tables 5 and 6 of this report. The expansion clip is fabricated from Type 316 stainless steel materials. The Type 316 stainless steel hexagonal steel nut conforms to ANSI B18.2.2-65 and the AISI Type 316 stainless steel washer conforms to ANSI/ASME B18.22.1 1965 (R1981). The Trubolt+ Wedge anchor body consists of a threaded section throughout the majority of its length and a wedge section at the far end. The expansion clip is formed around the anchor, just above the wedge. The expansion clip consists of a split cylindrical ring with undercutting grooves at the bottom end. During torquing of the anchor, the grooves in the expansion clip are designed to cut into the walls of the concrete hole as the wedge portion of the stud is forced upward against the interior of the clip. The Trubolt+ Wedge anchor is illustrated in Figure 1 of this report.

3.3 OVERHEAD Trubolt+ Wedge Anchor:

The OVERHEAD Trubolt+ Wedge Anchor is a torque-controlled, wedge-type mechanical expansion anchor, available in $\frac{3}{8}$ -inch (9.5 mm) diameter. The OVERHEAD Trubolt+ Wedge Anchor consists of a high-strength threaded anchor body, expansion clip, coupling nut and washer. The anchor body is cold-formed from low carbon steel materials with the mechanical properties (yield and ultimate strengths) as described in Tables 3 and 4 of this report. The zinc plating on the anchor body complies with ASTM B633 SC1, Type III, with a minimum 0.0002 inch (5 μ m) thickness. The expansion clip is fabricated from low carbon steel materials. The coupling nut consists of Grade 2 steel with $\frac{3}{8}$ " -16 threads throughout the length of the nut. The washer complies with ANSI/ASME B18.22.1 1965 (R1981). The OVERHEAD Trubolt+ Wedge anchor body consists of a threaded section throughout the majority of its length and a wedge section at the far end. The expansion clip is formed around the anchor, just above the wedge. The expansion clip consists of a split cylindrical ring with undercutting grooves at the bottom end. During torquing of the anchor (using coupling nut), the grooves in the expansion clip are designed to cut into the walls of the concrete hole as the wedge portion of the anchor body is forced upward against the interior of the clip (U.S. patent nos. 7,744,320 and 7,811,037). The OVERHEAD Trubolt+ Wedge anchor is illustrated in Figure 2 of this report.

3.4 Concrete:

Normal-weight and lightweight concrete must comply with Sections 1903 and 1905 of the IBC.

3.5 Steel Deck Panels:

Steel deck panels must comply with ASTM A653, SS Grade 40 (minimum), and must have a minimum 0.034-inch (0.864 mm) base-metal thickness (No. 20 gage).

4.0 DESIGN AND INSTALLATION

4.1 Strength Design:

4.1.1 General: Design strength of anchors complying with the 2015 IBC, as well as Section R301.1.3 of the 2015 IRC

must be determined in accordance with ACI 318-14 Chapter 17 and this report.

Design strength of anchors in accordance with the 2012 IBC, as well as Section R301.1.3 of the 2012 IRC, must be determined in accordance with ACI 318-11 Appendix D and this report.

Design strength of anchors in accordance with the 2009 IBC and Section R301.1.3 of the 2009 IRC must be in accordance with ACI 318-08 Appendix D and this report.

Design strength of anchors in accordance with the 2006 IBC and Section R301.1.3 of the 2006 IRC must be in accordance with ACI 318-05 Appendix D and this report.

Design parameters are based on the 2015 IBC (ACI 318-14) and 2012 IBC (ACI 318-11) unless noted otherwise in Sections 4.1.1 through 4.1.12 of this report.

The strength design of anchors must comply with ACI 318-14 17.3.1 or ACI 318-11 D.4.1, as applicable, except as required in ACI 318-14 17.2.3 or ACI 318-11 D.3.3, as applicable. Strength reduction factors, ϕ , as given in ACI 318-14 17.3.3 or ACI 318-11 D.4.3, as applicable, must be used for load combinations calculated in accordance with Section 1605.2 of the IBC and Section 5.3 of ACI 318-14 or Section 9.2 of ACI 318-11, as applicable. Strength reduction factors, ϕ , as given in ACI 318-11 D.4.4 must be used for load combinations calculated in accordance with ACI 318-11 Appendix C.

The value of f'_c used in calculations must be limited to 8,000 psi (55.2 MPa), maximum, in accordance with ACI 318-14 17.2.7 or ACI 318-11 D.3.7, as applicable. An example calculation in accordance with 2015 and 2012 IBC is provided in Table 7.

4.1.2 Requirements for Static Steel Strength in Tension, N_{sa} : The nominal static steel strength of a single anchor in tension, N_{sa} , calculated in accordance with ACI 318-14 17.4.1.2 or ACI 318-11 Section D.5.1.2, as applicable, is given in Tables 3 or 5 of this report. Strength reduction factors, ϕ , corresponding to ductile steel elements may be used for tension.

4.1.3 Requirements for Static Concrete Breakout Strength in Tension, N_{cb} , N_{cbg} : The nominal concrete breakout strength of a single anchor or a group of anchors in tension, N_{cb} or N_{cbg} respectively, must be calculated in accordance with ACI 318-14 17.4.2 or ACI 318-11 D.5.2, as applicable, with modifications as described in this section. The basic concrete breakout strength of a single anchor in tension, N_b , must be calculated in accordance with ACI 318-14 17.4.2.2 or ACI 318-11 D.5.2.2, as applicable, using the values of h_{ef} and k_{cr} as given in Tables 3 or 5 of this report. The nominal concrete breakout strength in tension in regions where analysis indicates no cracking in accordance with ACI 318-14 17.4.2.6 or ACI 318-11 D.5.2.6, as applicable, must be calculated with $\psi_{e,N} = 1.0$ and using the value of k_{unor} as given in Tables 3 or 5 of this report.

For anchors installed in the soffit of sand-lightweight or normal-weight concrete-filled steel deck floor and roof assemblies, as shown in Figure 7, calculation of the concrete breakout strength in accordance with ACI 318-14 17.4.2 or ACI 318-11 D.5.2, as applicable, is not required.

4.1.4 Requirements for Static Pullout Strength in Tension, N_{pn} : The nominal pullout strength of a single anchor in tension in accordance with ACI 318-14 17.4.3 or ACI 318-11 D.5.3, as applicable, in cracked and uncracked concrete, $N_{p,cr}$ or $N_{p,unor}$, respectively, is given in Tables 3 or 5 of this report. For all design cases, $\psi_{c,p} = 1.0$. In

accordance with ACI 318-14 17.4.3.2 or ACI 318-11 D.5.3.2, as applicable, the nominal pullout strength in tension must be calculated according to Eq-1.

$$N_{p,f_c} = N_{p,cr} \sqrt{\frac{f_c}{2,500}} \quad (\text{lb, psi}) \quad (\text{Eq-1})$$

$$N_{p,f_c} = N_{p,cr} \sqrt{\frac{f_c}{17.2}} \quad (\text{N, MPa})$$

In regions where analysis indicates no cracking in accordance with ACI 318-14 17.4.3.6 or ACI 318-11 D.5.3.6, as applicable, the nominal pullout strength in tension must be calculated according to Eq-2:

$$N_{p,f_c} = N_{p,uncr} \sqrt{\frac{f_c}{2,500}} \quad (\text{lb, psi}) \quad (\text{Eq-2})$$

$$N_{p,f_c} = N_{p,uncr} \sqrt{\frac{f_c}{17.2}} \quad (\text{N, MPa})$$

where values for $N_{p,cr}$ or $N_{p,uncr}$ are not provided in Tables 3 or 5 of this report, the pullout strength in tension need not be evaluated.

The nominal pullout strength in tension of the anchors installed in the soffit of sand lightweight or normal-weight concrete on steel deck floor and roof assemblies, as shown in Figure 7 of this report, is given in Table 9. In accordance with ACI 318-14 17.4.3.2 or ACI 318-11 D.5.3.2, as applicable, the nominal pullout strength in cracked concrete must be calculated according to Eq-1, whereby the value of $N_{p,deck,cr}$ must be substituted for $N_{p,cr}$ and the value 3,000 psi or 20.7 MPa must be substituted for 2,500 psi or 17.2 MPa. In regions where analysis indicates no cracking in accordance with ACI 318-14 17.4.3.6 or ACI 318-11 D.5.3.6, as applicable, the nominal pullout strength in tension must be calculated according to Eq-2, whereby the value of $N_{p,deck,uncr}$ must be substituted for $N_{p,uncr}$ and the value 3,000 psi or 20.7 MPa must be substituted for 2,500 psi or 17.2 MPa.

4.1.5 Requirements for Static Steel in Shear, V_{sa} : The values of V_{sa} for a single anchor given in Tables 4 or 6 of this report must be used in lieu of the values of V_{sa} derived by calculation according to ACI 318-14 17.5.1.2 or ACI 318-11 D.6.1.2, as applicable. Strength reduction factors, ϕ , corresponding to ductile steel elements may be used except for the carbon steel $3/8$ -inch-diameter (9.5 mm) anchors loaded in shear, which have a strength reduction factor corresponding to brittle steel elements.

The shear strength, $V_{sa,deck}$, of anchors installed in the soffit of sand lightweight or normal-weight concrete on steel deck floor and roof assemblies, as shown in Figure 7 of this report, is given in Table 9 of this report.

4.1.6 Requirements for Static Concrete Breakout Strength in Shear, V_{cb} or V_{cbg} : The nominal static concrete breakout strength in shear of a single anchor or a group of anchors, V_{cb} or V_{cbg} , must be calculated in accordance with ACI 318-14 17.5.2 or ACI 318-11 D.6.2, as applicable. The basic concrete breakout strength in shear of a single anchor in cracked concrete, V_b , must be calculated in accordance with ACI 318-14 17.5.2.2 or ACI 318-11 D.6.2.2, as applicable, using the value of d_a , given in Table 2 of this report, and the value l_a , given in Tables 4 or 6, must be taken no greater than h_{ef} . In no cases must l_a exceed $8d_a$.

For anchors installed in the soffit of sand lightweight or normal-weight concrete on steel deck floor and roof assemblies, as shown in Figure 7, calculation of the concrete breakout strength in accordance with ACI 318-14 17.5.2 or ACI 318-11 D.6.2, as applicable, is not required.

4.1.7 Requirements for Static Concrete Pryout Strength of Anchor in Shear, V_{cp} or $V_{cp,g}$: The nominal static concrete pryout strength in shear of a single anchor or groups of anchors, V_{cp} or $V_{cp,g}$, must be calculated in accordance with ACI 318-14 17.5.3 or ACI 318-11 D.6.3, as applicable, modified by using the value of k_{cp} provided in Tables 4 and 6 of this report and the value of N_{cb} or N_{cbg} as calculated in Section 4.1.3 of this report.

For anchors installed in the soffit of sand-lightweight or normal-weight concrete on steel deck floor and roof assemblies, as shown in Figure 7 of this report, calculation of the concrete pryout strength in accordance with ACI 318-14 17.5.3 or ACI 318-11 D.6.3 is not required.

4.1.8 Requirements for Minimum Member Thickness, Minimum Anchor Spacing and Minimum Edge Distance: Values of s_{min} and c_{min} as given in Table 2 of this report must be used in lieu of ACI 318-14 17.7.1 and 17.7.3 or ACI 318-11 D.8.1 and D.8.3, respectively, as applicable. Minimum member thicknesses, h_{min} , as given in Tables 2 through 6 of this report, must be used in lieu of ACI 318-14 17.7.5 or ACI 318-11 D.8.5, as applicable.

For anchors installed in the soffit of sand-lightweight or normal-weight concrete on steel deck floor and roof assemblies, the anchors must be installed in accordance with Figure 7 of this report and the minimum anchor spacing along the flute must be the greater of $3h_{ef}$ or 1.5 times the flute width.

4.1.9 Requirements for Critical Edge Distance and Splitting: In applications where $c < c_{ac}$ and supplemental reinforcement to control splitting of the concrete is not present, the concrete breakout strength in tension for uncracked concrete, calculated according to ACI 318-14 17.4.2 or ACI 318-11 D.5.2, as applicable, must be further multiplied by the factor $\psi_{cp,N}$ given by Eq-3:

$$\psi_{cp,N} = c / c_{ac} \quad (\text{Eq-3})$$

whereby the factor $\psi_{cp,N}$ need not be taken as less than $1.5h_{ef} / c_{ac}$. For all other cases $\psi_{cp,N} = 1.0$. Values for the critical edge distance c_{ac} must be taken from Tables 3 or 5 of this report.

4.1.10 Requirements for Seismic Design:

4.1.10.1 General: For load combinations including earthquake, the design must be performed according to ACI 318-14 17.2.3 or ACI 318-11 D.3.3, as applicable. Modifications to ACI 318-14 17.2.3 shall be applied under Section 1905.1.8 of the 2015 IBC. For the 2012 IBC, Section 1905.1.9 is omitted. Modifications to ACI 318 (-08, -05) D.3.3 must be applied under Section 1908.1.9 of the 2009 IBC or Section 1908.1.16 of the 2006 IBC, as applicable.

The carbon steel $1/2$ -inch- $5/8$ -inch- and $3/4$ -inch-diameter (12.7, 15.9 and 19.1 mm), stainless steel $1/2$ -inch (12.7 mm) and $5/8$ -inch (15.9 mm) anchors loaded in tension and shear, along with the $3/8$ -inch-diameter (9.5 mm) anchor loaded in tension only, comply with ACI 318-14 2.3 or ACI 318-11 D.1, as applicable, as ductile steel elements and must be designed in accordance with ACI 318-14, 17.2.3.4, 17.2.3.5, 17.2.3.6 or 17.2.3.7; ACI 318-11 D.3.3.4, D.3.3.5, D.3.3.6, or D.3.3.7; ACI 318-08 D.3.3.4, D.3.3.5, or D.3.3.6; or ACI 318-05 D.3.3.4 or D.3.3.5, as applicable.

The carbon steel $3/8$ -inch-diameter (9.5 mm) anchor loaded in shear must be designed in accordance with ACI 318-14 17.2.3.5.3, ACI 318-11 D.3.3.5.3, ACI 318-08 D.3.3.5 or D.3.3.6, or ACI 318-05 D.3.3.6 as brittle steel elements, as applicable.

4.1.10.2 Seismic Tension: The nominal steel strength and nominal concrete breakout strength for anchors in tension must be calculated according to ACI 318-14 17.4.1 and 17.4.2 or ACI 318-11 D.5.1 and D.5.2, respectively, as applicable, as described in Sections 4.1.2 and 4.1.3 of this report. In accordance with ACI 318-14 17.4.3.2 or ACI 318-11 D.5.3.2, as applicable, the value for nominal pullout strength tension for seismic loads, N_{eq} or $N_{p,deck,cr}$, given in Table 3, 5 or 9 of this report, must be used in lieu of N_p . The values of N_{eq} must be adjusted for the concrete strength in accordance with Eq-4:

$$N_{eq,f'c} = N_{eq} \sqrt{\frac{f'_c}{2,500}} \quad (\text{lb, psi}) \quad (\text{Eq-4})$$

$$N_{eq,f'c} = N_{eq} \sqrt{\frac{f'_c}{17.2}} \quad (\text{N, MPa})$$

The value of $N_{p,deck,cr}$ must be calculated according to Eq-4, whereby the value 3,000 psi or 20.7 MPa must be substituted for 2,500 psi or 17.2 MPa.

If no values for N_{eq} are given in Tables 3 or 5, the static design strength values govern. Section 4.1.4 provides additional requirements.

4.1.10.3 Seismic Shear: The nominal concrete breakout strength and pryout strength for anchors in shear must be calculated according to ACI 318-14 17.5.2 and 17.5.3 or ACI 318-11 D.6.2 and D.6.3, respectively, as applicable, as described in Sections 4.1.6 and 4.1.7 of this report. In accordance with ACI 318-14 17.5.1.2 or ACI 318-11 D.6.1.2, as applicable, the value for nominal steel strength in shear for seismic loads, V_{eq} , or $V_{sa,deck}$, given in Tables 4, 6 or 9 of this report, must be used in lieu of V_{sa} .

4.1.11 Interaction of Tensile and Shear Forces: For designs that include combined tension and shear, the interaction of tension and shear loads must be calculated in accordance with ACI 318-14 17.6 or ACI 318-11 D.7, as applicable.

4.1.12 Lightweight Concrete: For the use of anchors in lightweight concrete, the modification factor λ_a equal to 0.8λ is applied to all values of $\sqrt{f'_c}$ affecting N_n and V_n .

For ACI 318-14 (2015 IBC), ACI 318-11 (2012 IBC) and ACI 318-08 (2009 IBC), λ shall be determined in accordance with the corresponding version of ACI 318.

For ACI 318-05 (2006 IBC), λ shall be taken as 0.75 for all lightweight concrete and 0.85 for sand-lightweight concrete. Linear interpolation shall be permitted if partial sand replacement is used. In addition, the pullout strengths $N_{p,cr}$, $N_{p,uncr}$, and N_{eq} shall be multiplied by the modification factor, λ_a , as applicable.

For anchors installed in the soffit of sand-lightweight concrete-filled steel deck and floor and roof assemblies, further reduction of the pullout values provided in this report is not required.

4.2 Allowable Stress Design (ASD):

4.2.1 General: For anchors designed using load combinations in accordance with IBC Section 1605.3, allowable loads must be established using Eq-5 and Eq-6:

$$T_{allowable,ASD} = \phi N_n / \alpha \quad (\text{Eq-5})$$

and

$$V_{allowable,ASD} = \phi V_n / \alpha \quad (\text{Eq-6})$$

where

$T_{allowable,ASD}$ = Allowable tension load (lbf or kN).

$V_{allowable,ASD}$ = Allowable shear load (lbf or kN).

ϕN_n = Lowest design strength of an anchor or anchor group in tension as determined in accordance with ACI 318-14 Chapter 17 and 2015 IBC Section 1905.1.8, ACI 318-11 Appendix D, ACI 318-08 Appendix D and 2009 IBC Section 1908.1.9 and ACI 318-05 Appendix D and 2006 IBC Section 1908.1.16, and Section 4.1 of this report, as applicable.

ϕV_n = Lowest design strength of an anchor or anchor group in shear as determined in accordance with ACI 318-14 Chapter 17 and 2015 IBC Section 1905.1.8, ACI 318-11 Appendix D, ACI 318-08 Appendix D and 2009 IBC Section 1908.1.9, ACI 318-05 Appendix D and 2006 IBC Section 1908.1.16, and Section 4.1 of this report, as applicable.

α = Conversion factor calculated as a weighted average of the load factors for the controlling load combination. In addition, α must include all applicable factors to account for nonductile failure modes and required over-strength.

An example of allowable stress design values for illustrative purposes is shown in Table 7 of this report.

4.2.2 Interaction of Tensile and Shear Forces: In lieu of ACI 318-14 17.6.1, 17.6.2 and 17.6.3 or ACI 318 (-11, -08, -05) D.7.1, D.7.2 and D.7.3, interaction must be calculated as follows:

For shear loads $V \leq 0.2 V_{allowable, ASD}$, the full allowable load in tension, $T_{allowable, ASD}$, may be taken.

For tension loads $T \leq 0.2 T_{allowable, ASD}$, the full allowable load in shear, $V_{allowable, ASD}$, may be taken.

For all other cases, Eq-7 applies:

$$T/T_{allowable, ASD} + V/V_{allowable, ASD} \leq 1.2 \quad (\text{Eq-7})$$

For the OVERHEAD Trubolt+ Wedge Anchor, the influence of bending on the tension capacity when loaded in shear must be considered.

4.3 Installation:

Installation parameters are provided in Tables 2 and 8 and Figures 4, 5, and 6 of this report. Anchor locations must comply with this report and the plans and specifications approved by the code official. The Trubolt+ Wedge Anchors must be installed according to ITW's published instructions and this report. Holes must be predrilled in concrete with a compressive strength from 2,500 to 8,500 psi (17.2 to 58.6 MPa) [minimum of 24 MPa is required under ADIBC Appendix L, Section 5.1.1] at time of installation, using carbide-tipped masonry drill bits manufactured within the range of the maximum and minimum drill tip dimensions of ANSI Standard B212.15-1994. The nominal drill bit diameter must be equal to that of the anchor size. The minimum drilled hole depth, h_a , must comply with Table 2 of this report. Embedment, spacing, edge distance, and minimum concrete thickness must comply with Table 2. The predrilled holes must be cleaned to remove loose particles, using pressurized air or a vacuum. For the RED HEAD Trubolt+ Wedge Anchor, the hex nut and washer must be assembled on the end of the anchor, leaving the nut flush with the end of the anchor. For the OVERHEAD Trubolt+ Wedge Anchor, the

coupling nut and washer must be assembled on the end of the anchor to obtain at least $\frac{1}{2}$ inch (12.7 mm) thread engagement on the anchor). The anchors must be hammered into the predrilled hole to the required embedment depth in concrete. Where a fixture is installed, the anchors must be hammered through the fixture into the predrilled hole to the required embedment depth into the concrete. The nut must be tightened against the washer until the specified torque values listed in Table 2 are achieved.

For installation in the soffit of sand-lightweight or normal-weight concrete on steel deck floor and roof assemblies, the hole diameter in the steel deck must not exceed the diameter of the hole in the concrete by more than $\frac{1}{8}$ inch (3.2 mm) and concrete must have a minimum compressive strength of 3,000 psi (20.7 MPa) [minimum of 24 MPa is required under ADIBC Appendix L, Section 5.1.1] at time of installation. For member thickness, edge distance, spacing restrictions, and installations torque values for installation into the soffit of sand lightweight or normal-weight concrete on steel deck floor and roof assemblies, see Figure 7, Table 8, and Section 4.1.8 of this report.

4.4 Special Inspection:

Periodic special inspection is required, in accordance with Section 1705.1.1 and Table 1705.3 of the 2015 IBC and 2012 IBC; Section 1704.15 and Table 1704.4 of the 2009 IBC; or Section 1704.13 of the 2006 IBC, as applicable. The special inspector must make periodic inspections during anchor installation to verify anchor type, anchor dimensions, concrete type, concrete compressive strength, drill bit type, hole dimensions, hole cleaning procedures, edge distance, anchor spacing, concrete member thickness, anchor embedment, tightening torque, and adherence to the manufacturer's published installation instructions. The special inspector must be present as often as required in accordance with the statement of special inspection. Under the IBC, additional requirements as set forth in Sections 1705, 1706, and 1707 must be observed, where applicable.

5.0 CONDITIONS OF USE

The Trubolt+ Wedge Anchors described in this report comply with, or are suitable alternatives to what is specified in, those codes listed in Section 1.0 of this report, subject to the following conditions.

- 5.1 The anchors must be installed in accordance with ITW's published instructions and this report. In case of conflicts, this report governs.
- 5.2 Anchor sizes, dimensions, and installation parameters are as set forth in this report.
- 5.3 The anchors are limited to installation in cracked and uncracked, normal-weight or lightweight concrete having a specified compressive strength, f'_c , of 2,500 psi to 8,500 psi (17.2 MPa to 58.6 MPa) [minimum of 24 MPa is required under ADIBC Appendix L, Section 5.1.1]. The anchors may also be installed in cracked and uncracked normal-weight or sand-lightweight concrete over profile steel deck having a minimum specified compressive strength, f'_c , of 3,000 psi (20.7 MPa) [minimum of 24 MPa is required under ADIBC Appendix L, Section 5.1.1].
- 5.4 The values of f'_c used for calculation purposes must not exceed 8,000 psi (55.0 MPa).
- 5.5 Strength design values must be established in accordance with Section 4.1 of this report.
- 5.6 Allowable design values must be established in accordance with Section 4.2 of this report.

- 5.7 Anchor spacing, edge distance, and minimum member thickness must comply with Tables 2 and 8 and Figures 4, 5, and 6 of this report.
- 5.8 Prior to installation, calculations and details justifying that the applied loads comply with this report must be submitted to the code official for approval. The calculations and details must be prepared by a registered design professional where required by the statutes of the jurisdiction in which the project is to be constructed.
- 5.9 Since an ICC-ES acceptance criteria for evaluating data to determine the performance of expansion anchors subjected to fatigue or shock loading is unavailable at this time, the use of these anchors under such conditions is beyond the scope of this report.
- 5.10 Anchors may be installed in regions of concrete where cracking has occurred or where analysis indicates cracking may occur ($f_i > f_r$), subject to the conditions of this report.
- 5.11 Anchors may be used to resist short-term loading due to wind or seismic forces, subject to the conditions of this report.
- 5.12 Where not otherwise prohibited in the code, Trubolt+ Wedge Anchors are permitted for use with fire-resistance-rated construction provided that at least one of the following conditions is fulfilled:
 - Anchors are used to resist wind or seismic forces only.
 - Anchors that support a fire-resistance-rated envelope or a fire-resistance-rated membrane are protected by approved fire-resistance-rated materials, or have been evaluated for resistance to fire exposure in accordance with recognized standards.
 - Anchors are used to support nonstructural elements.
- 5.13 Use of the zinc plated, carbon steel anchors is limited to dry, interior locations.
- 5.14 Special inspections are provided in accordance with Section 4.4 of this report.
- 5.15 The anchors are manufactured in the USA; under a quality-control program with inspections by ICC-ES.

6.0 EVIDENCE SUBMITTED

Data complying with the ICC-ES Acceptance Criteria for Mechanical Anchors in Concrete Elements (AC193), dated October 2015, for use in cracked and uncracked concrete, including optional tests for seismic tension and shear; profile steel deck soffit tests; and quality control documentation.

7.0 IDENTIFICATION

The anchors are identified by their dimensional characteristics and the anchor size, and by a length identification marking stamped on the anchor, as indicated in Table 1 of this report. The anchors have the length identification marking underlined on the anchor head, as illustrated in Figure 3 of this report, and this is visible after installation for verification. Packages are identified with the anchor name, material (carbon or stainless) type and size; the manufacturer's name (ITW Red Head, ITW Brands, or ITW Buildex) and address; and the evaluation report number (ESR-2427).

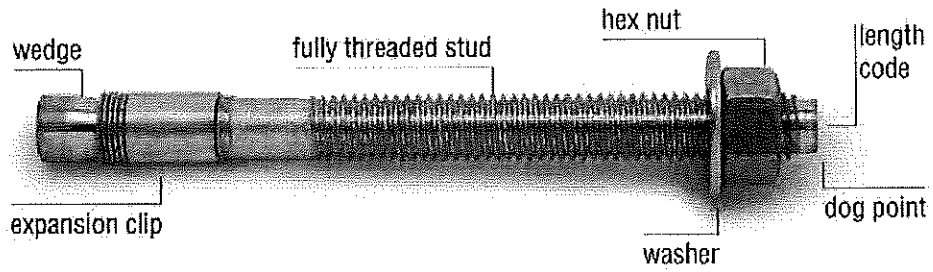

FIGURE 1—ITW RED HEAD TRUBOLT+ WEDGE ANCHOR (Carbon and Stainless Steel)

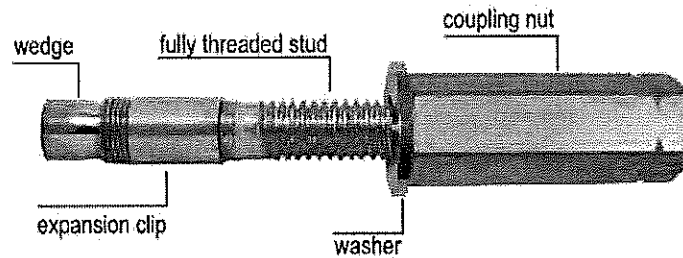

FIGURE 2—OVERHEAD TRUBOLT+ WEDGE ANCHOR

TABLE 1—LENGTH IDENTIFICATION MARKINGS¹

| LENGTH (inches) | ID MARKING ON ANCHOR HEAD | | | | | | | | | | | | |
|--------------------------|---------------------------|-------|-------|-------|-------|-------|-------|-------|-------|-------|-------|-------|-------|
| | C | D | E | F | G | H | I | J | K | L | M | N | O |
| From | 2 1/2 | 3 | 3 1/2 | 4 | 4 1/2 | 5 | 5 1/2 | 6 | 6 1/2 | 7 | 7 1/2 | 8 | 8 1/2 |
| Up to, but not including | 3 | 3 1/2 | 4 | 4 1/2 | 5 | 5 1/2 | 6 | 6 1/2 | 7 | 7 1/2 | 8 | 8 1/2 | 9 |

For SI: 1 inch = 25.4 mm.

¹Figure 3 shows a typical marking.

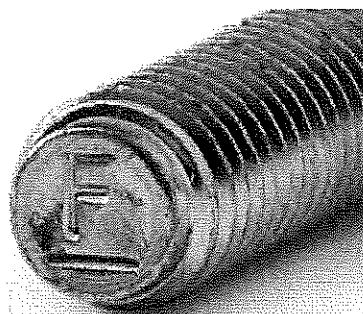

FIGURE 3—TRUBOLT+ WEDGE ANCHOR LENGTH IDENTIFICATION MARKING

TABLE 2—ITW RED HEAD TRUBOLT+ WEDGE ANCHOR AND OVERHEAD TRUBOLT+ WEDGE ANCHOR INSTALLATION INFORMATION (CARBON STEEL AND STAINLESS STEEL)¹

| PARAMETER | NOTATION | UNITS | NOMINAL ANCHOR DIAMETER (inch) | | | | | | | | | |
|--|-------------------------|--------|--------------------------------|----------------|----------------|----------------|----------------|----------------|----------------|----------------|----------------|----|
| | | | $\frac{3}{8}$ | | $\frac{1}{2}$ | | $\frac{5}{8}$ | | $\frac{3}{4}$ | | | |
| Anchor outer diameter | $d_a[d_o]$ ³ | inches | 0.361 | | 0.5 | | 0.615 | | 0.7482 | | | |
| Nominal carbide bit diameter | d_{bit} | inches | $\frac{3}{8}$ | | $\frac{1}{2}$ | | $\frac{5}{8}$ | | $\frac{3}{4}$ | | | |
| Effective embedment depth | h_{ef} | inches | $1\frac{5}{8}$ | | 2 | | $3\frac{1}{4}$ | | $4\frac{1}{4}$ | | | |
| Minimum anchor embedment depth | h_{nom} | inches | 2 | | $2\frac{1}{2}$ | | $3\frac{3}{4}$ | | $4\frac{3}{4}$ | | | |
| Minimum hole depth ¹ | h_o | inches | $2\frac{1}{4}$ | | $2\frac{3}{4}$ | | 4 | | $3\frac{1}{2}$ | | | |
| Minimum concrete member thickness ¹ | h_{min} | inches | 4 | 5 | 4 | 6 | 6 | 8 | 6 | $6\frac{1}{4}$ | 7 | 8 |
| Critical edge distance ¹ | c_{ac} | In. | 5 | 3 | 6 | 6 | $7\frac{1}{2}$ | 6 | $7\frac{1}{2}$ | $6\frac{1}{2}$ | 12 | 10 |
| Minimum anchor spacing ¹ | s_{min} | In. | $3\frac{1}{2}$ | $2\frac{1}{2}$ | 6 | $5\frac{3}{4}$ | 4 | $5\frac{3}{4}$ | 8 | 6 | 6 | 6 |
| Minimum edge distance ² | c_{min} | In. | 3 | | 6 | | | $7\frac{1}{2}$ | 5 | $7\frac{1}{2}$ | $7\frac{1}{2}$ | |
| Minimum overall anchor length | l_{anchor} | inches | $2\frac{1}{2}$ | | $3\frac{3}{4}$ | | $4\frac{1}{2}$ | | $4\frac{1}{4}$ | | 6 | |
| Installation torque | T_{inst} | ft-lb | 30 | | 45 | | | 90 | | 110 | | |
| Minimum diameter of hole in fastened part | d_h | inches | $\frac{1}{2}$ | | $\frac{5}{8}$ | | | $\frac{3}{4}$ | | $\frac{7}{8}$ | | |

For SI: 1 inch = 25.4 mm, 1 ft-lb = 1.356 N-m.

¹Stainless steel anchors are available in $\frac{1}{2}$ -inch and $\frac{5}{8}$ -inch-diameters. The OVERHEAD version is available in a carbon steel $\frac{3}{8}$ -inch-diameter.

²For installation of the carbon steel anchors in the soffit of concrete on steel deck floor or roof assemblies, see Figure 7. Anchors in the lower and in the upper flute may be installed with a maximum 1-inch offset in either direction from the center of the flute. In addition, anchors must have an axial spacing along the flute equal to the greater of $3h_{ef}$ or 1.5 times the flute width.

³The notation in brackets is for the 2006 IBC.

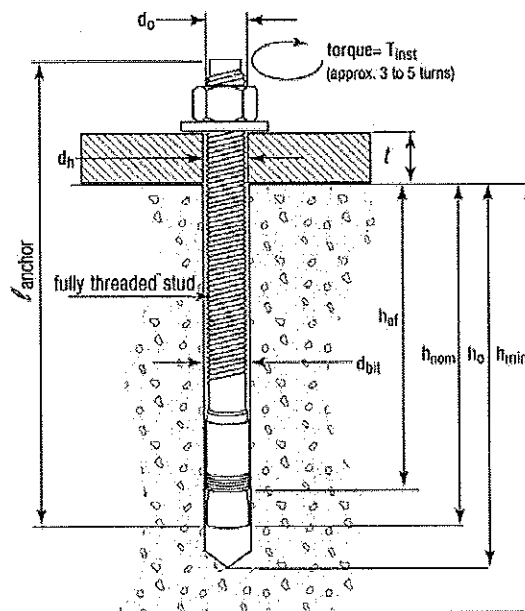

FIGURE 4—ITW RED HEAD TRUBOLT+ WEDGE ANCHOR (INSTALLED)

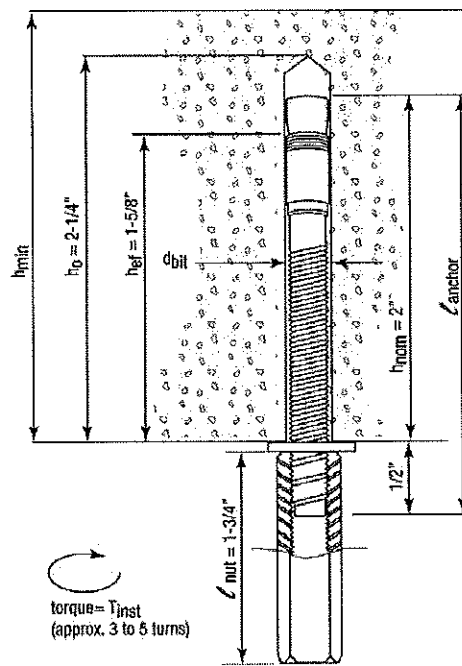
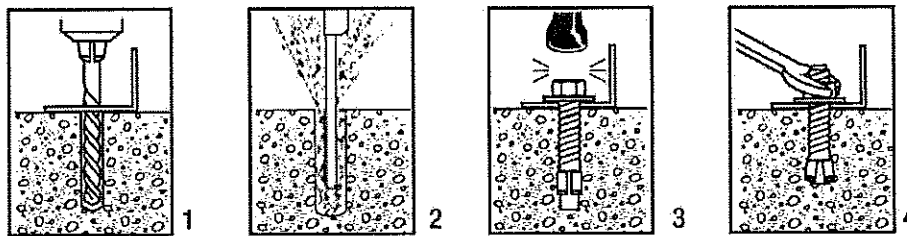

FIGURE 5—OVERHEAD TRUBOLT+ WEDGE ANCHOR (INSTALLED),
³/₈ INCH NOMINAL ANCHOR DIAMETER (d_o)



1. Select a carbide drill bit with a diameter equal to the anchor diameter. Drill hole 1/4" deeper than anchor embedment.
2. Clean hole with pressurized air or vacuum to remove any excess dust/debris.
3. Using the washer and nut provided, assemble the anchor, leaving nut one half turn from the end of anchor to protect threads. Drive anchor through fixture to be fastened until washer is flush to surface of fixture.
4. Expand anchor by tightening nut to the specified setting torque (approx 3-5 turns).

FIGURE 6—INSTALLATION INSTRUCTIONS

TABLE 3—ITW RED HEAD CARBON STEEL TRUBOLT+ WEDGE ANCHOR AND OVERHEAD TRUBOLT+ WEDGE ANCHOR TENSION DESIGN INFORMATION^{1,2,3,9}

| CHARACTERISTIC | SYMBOL | UNITS | NOMINAL ANCHOR DIAMETER (inch) ⁶ | | | | | | | |
|--|-----------------------|-----------------|---|----------------|-----------------------------|----------------|-------------------------------|----------------|---|--|
| | | | ³ / ₈ | | ¹ / ₂ | | ⁵ / ₈ | | ³ / ₄ | |
| Anchor category | 1, 2 or 3 | — | 1 | | 1 | | 1 | | 1 | |
| Minimum effective embedment depth | h_{ef} | In. | 1 ⁵ / ₈ | | 2 | | 3 ¹ / ₄ | | 2 ³ / ₄ , 4 ¹ / ₄ , 3 ³ / ₄ | |
| Minimum concrete member thickness | h_{min} | In. | 4 | 5 | 4 | 6 | 6 | 8 | 6 | 6 ¹ / ₄ , 7, 8 |
| Critical edge distance | c_{ec} | In. | 5 | 3 | 6 | 6 | 7 ¹ / ₂ | 6 | 7 ¹ / ₂ | 6 ¹ / ₂ , 12, 10 |
| Data for Steel Strengths – Tension | | | | | | | | | | |
| Minimum specified yield strength | f_y | psi | 60,000 | | 55,000 | | 55,000 | | 55,000 | |
| Minimum specified ultimate strength | f_{uta} | psi | 75,000 | | 75,000 | | 75,000 | | 75,000 | |
| Effective tensile stress area (neck) | $A_{se,N} [A_{se}]^8$ | in ² | 0.056 | | 0.119 | | 0.183 | | 0.266 | |
| Steel strength in tension | N_{so} | lbf | 4,200 | | 8,925 | | 13,725 | | 19,950 | |
| Strength reduction factor ϕ for tension, steel failure modes ⁴ | ϕ | — | 0.75 | | 0.75 | | 0.75 | | 0.75 | |
| Data for Concrete Breakout Strengths in Tension | | | | | | | | | | |
| Effectiveness factor - uncracked concrete | k_{uncr} | — | 24 | | 24 | | 24 | | 24 | |
| Effectiveness factor - cracked concrete | k_{cr} | — | 17 | | 17 | | 17 | | 17 | |
| Modification factor for cracked and uncracked concrete ⁵ | $\psi_{e,N}$ | — | 1.0 | | 1.0 | | 1.0 | | 1.0 | |
| Strength reduction factor ϕ for tension, concrete failure modes, Condition B ⁴ | ϕ | — | 0.65 | | 0.65 | | 0.65 | | 0.65 | |
| Data for Pullout Strengths | | | | | | | | | | |
| Pullout strength, uncracked concrete | $N_{p,uncr}$ | lbf | See Footnote 7 | See Footnote 7 | 6,540 | 5,430 | 8,900 | See Footnote 7 | See Footnote 7 | See Footnote 7 |
| Pullout strength, cracked concrete | $N_{p,cr}$ | lbf | See Footnote 7 | See Footnote 7 | See Footnote 7 | See Footnote 7 | See Footnote 7 | See Footnote 7 | See Footnote 7 | See Footnote 7 |
| Pullout strength for seismic loads | N_{eq} | lbf | See Footnote 7 | See Footnote 7 | See Footnote 7 | See Footnote 7 | 6,715 | See Footnote 7 | See Footnote 7 | See Footnote 7 |
| Strength reduction factor ϕ for tension, pullout failure modes, Condition B ⁴ | ϕ | — | See Footnote 7 | See Footnote 7 | 0.65 | 0.65 | 0.65 | See Footnote 7 | See Footnote 7 | See Footnote 7 |
| Additional Anchor Data | | | | | | | | | | |
| Axial stiffness in service load range in uncracked concrete | β_{uncr} | lbf /in | 100,000 | 250,000 | 250,000 | 250,000 | 250,000 | 250,000 | 250,000 | 250,000 |
| Axial stiffness in service load range in cracked concrete | β_{cr} | lbf /in | 40,000 | 20,000 | 20,000 | 20,000 | 20,000 | 20,000 | 20,000 | 20,000 |

For SI: 1 inch = 25.4 mm, 1 in² = 645.16 mm², 1 lbf = 4.45 N, 1 psi = 0.006895 MPa, 1 lbf · 10²/in = 17,500 N/m.

¹The data in this table is intended to be used with the design provisions of ACI 318-14 Chapter 17 or ACI 318-11 Appendix D, as applicable; for anchors resisting seismic load combinations, the additional requirements of ACI 318-14 17.2.3 or ACI 318-11 D.3.3, as applicable, shall apply.

²Installation must comply with the manufacturers printed installation instructions and details.

³The ³/₈-, ¹/₂-, ⁵/₈-, and ³/₄-inch diameter Trubolt + Wedge Anchors are ductile steel elements under tension loading as defined by ACI 318-14 2.3 or ACI 318-11 D.1, as applicable.

⁴All values of ϕ apply to the load combinations of IBC Section 1605.2, ACI 318-14 Section 5.3 or ACI 318-11 Section 9.2, as applicable. If the load combinations of ACI 318-11 Appendix C are used, then the appropriate value of ϕ must be determined in accordance with ACI 318-11 D.4.4. For installations where reinforcement that complies with ACI 318-14 Chapter 17 or ACI 318-11 Appendix D, as applicable, requirements for Condition A is present, the appropriate ϕ factor must be determined in accordance with ACI 318-14 17.3.3 or ACI 318-11 D.4.3, as applicable.

⁵For all design cases $\psi_{e,N} = 1.0$. The appropriate effectiveness factor for cracked concrete (k_{cr}) or uncracked concrete (k_{uncr}) must be used.

⁶The actual diameter for the ³/₈-inch diameter anchor is 0.361 inch, for the ⁵/₈-inch diameter anchor is 0.615-inch, and for the ³/₄-inch diameter anchor is 0.7482-inch.

⁷Anchor pullout strength does not control anchor design. Determine steel and concrete capacities only.

⁸The notation in brackets is for the 2006 IBC.

⁹The OVERHEAD version is available in a carbon steel ³/₈-inch-diameter only.

TABLE 4—ITW RED HEAD CARBON STEEL TRUBOLT+ WEDGE ANCHOR AND OVERHEAD TRUBOLT+ WEDGE ANCHOR SHEAR DESIGN INFORMATION^{1,2,3,8}

| CHARACTERISTIC | SYMBOL | UNITS | NOMINAL ANCHOR DIAMETER (inch) ⁵ | | | | | | | | | | |
|--|------------------------|-----------------|---|---|-----------------------------|-------------------------------|-------------------------------|-------------------------------|-------------------------------|-------------------------------|----|-------------------------------|-------------------------------|
| | | | ³ / ₈ | | ¹ / ₂ | | | ⁵ / ₈ | | ³ / ₄ | | | |
| Anchor category | 1, 2 or 3 | — | 1 | | 1 | | | 1 | | 1 | | | |
| Minimum effective embedment depth | h_{ef} | ln. | ¹ / ₂ | | 2 | | | 3 ¹ / ₄ | | 2 ³ / ₄ | | 4 ¹ / ₄ | 3 ³ / ₄ |
| Minimum concrete member thickness | h_{min} | ln. | 4 | 5 | 4 | 6 | 6 | 8 | 6 | 6 ¹ / ₄ | 7 | 8 | |
| Critical edge distance | c_{ac} | ln. | 5 | 3 | 6 | 6 | 7 ¹ / ₂ | 6 | 7 ¹ / ₂ | 6 ¹ / ₂ | 12 | 10 | |
| Data for Steel Strengths – Shear | | | | | | | | | | | | | |
| Minimum specified yield strength | f_y | psi | 60,000 | | 55,000 | | | 55,000 | | 55,000 | | | |
| Minimum specified ultimate strength | f_{ult} | psi | 75,000 | | 75,000 | | | 75,000 | | 75,000 | | | |
| Effective shear stress area (thread) | $A_{se}, V [A_{se}]^7$ | in ² | 0.075 | | 0.142 | | | 0.217 | | 0.332 | | | |
| Steel strength in shear, uncracked or cracked concrete ⁶ | V_{sa} | lbf | 1,830 | | 5,175 | | | 8,955 | | 14,970 | | | |
| Steel strength in shear - seismic loads | V_{saq} | lbf | 1,545 | | 5,175 | | | 8,955 | | 11,775 | | | |
| Strength reduction factor ϕ for shear, steel failure modes ⁴ | ϕ | — | 0.60 | | 0.65 | | | 0.65 | | 0.65 | | | |
| Data for Concrete Breakout and Concrete Pryout Strengths – Shear | | | | | | | | | | | | | |
| Coefficient for pryout strength | k_{cp} | — | 1.0 | | 1.0 | 2.0 | | 2.0 | | 2.0 | | | |
| Load-bearing length of anchor | l_e | in | ¹ / ₂ | | 2 | 3 ¹ / ₄ | | 2 ³ / ₄ | 4 ¹ / ₄ | 3 ³ / ₄ | | | |
| Strength reduction factor ϕ for shear, concrete failure modes, Condition B ⁴ | ϕ | — | 0.70 | | 0.70 | | | 0.70 | | 0.70 | | | |

For SI: 1 inch = 25.4 mm, 1 in² = 645.16 mm², 1 lbf = 4.45 N, 1 psi = 0.006895 MPa, 1 lbf · 10²/in = 17,500 N/m.

¹The data in this table is intended to be used with the design provisions of ACI 318-14 Chapter 17 or ACI 318-11 Appendix D, as applicable; for anchors resisting seismic load combinations, the additional requirements of ACI 318-14 17.2.3 or ACI 318-11 D.3.3, as applicable, shall apply.

²Installation must comply with the manufacturers printed installation instructions and details.

³The ¹/₂-, ⁵/₈-, and ³/₄-inch diameter Trubolt + Wedge Anchors are ductile steel elements under shear loading as defined by ACI 318-14 2.3 or ACI 318-11 D.1. The ³/₈" diameter Trubolt + is considered brittle under shear loading.

⁴All values of ϕ apply to the load combinations of IBC Section 1605.2, ACI 318-14 5.3 or ACI 318-11 Section 9.2, as applicable. If the load combinations of ACI 318-11 Appendix C are used, the appropriate value of ϕ must be determined in accordance with ACI 318-11 D.4.4. For installations where reinforcement that complies with ACI 318-14 Chapter 17 or ACI 318-11 Appendix D requirements for Condition A is present, the appropriate ϕ factor must be determined in accordance with ACI 318-14 17.3.3 or ACI 318-11 D.4.3, as applicable.

⁵The actual diameter for the ³/₈" diameter anchor is 0.361-inch, for the ⁵/₈" diameter anchor is 0.615-inch, and for the ³/₄" diameter anchor is 0.7482".

⁶Steel strength in shear values are based on test results per ACI 355.2, Section 9.4 and must be used for design.

⁷The notation in brackets is for the 2006 IBC.

⁸The OVERHEAD version is available in a carbon steel ³/₈-inch-diameter only.

1024

TABLE 5—ITW RED HEAD STAINLESS STEEL TRUBOLT+ WEDGE ANCHOR TENSION DESIGN INFORMATION^{1,2,3}

| CHARACTERISTIC | SYMBOL | UNITS | NOMINAL ANCHOR DIAMETER (inch) ⁶ | | | | | | |
|--|-----------------------|-----------------|---|----------------|-------------------------------|-----------------------------|-------------------------------|-------------------------------|-------------------------------|
| | | | ¹ / ₂ | | | ⁵ / ₈ | | | |
| Anchor category | 1, 2 or 3 | — | 1 | | | 1 | | | |
| Minimum effective embedment depth | h_{ef} | In. | 2 | | 3 ¹ / ₄ | | 2 ³ / ₄ | | 4 ¹ / ₄ |
| Minimum concrete member thickness | h_{min} | In. | 4 | 6 | 6 | 8 | 6 | 6 ¹ / ₄ | |
| Critical edge distance | c_{ac} | In. | 6 | 6 | 7 ¹ / ₂ | 6 | 7 ¹ / ₂ | 6 ¹ / ₂ | |
| Data for Steel Strengths – Tension | | | | | | | | | |
| Minimum specified yield strength | f_y | psi | 65,000 | | | 65,000 | | | |
| Minimum specified ultimate strength | f_{uta} | psi | 100,000 | | | 100,000 | | | |
| Effective tensile stress area (neck) | $A_{sa,N} (A_{sa})^8$ | in ² | 0.119 | | | 0.183 | | | |
| Steel strength in tension | N_{sa} | lbf | 11,900 | | | 18,300 | | | |
| Strength reduction factor ϕ for tension, steel failure modes ⁴ | ϕ | — | 0.75 | | | 0.75 | | | |
| Data for Concrete Breakout Strengths in Tension | | | | | | | | | |
| Effectiveness factor - uncracked concrete | k_{uncr} | — | 24 | | | 24 | | | |
| Effectiveness factor - cracked concrete | k_{cr} | — | 17 | | | 17 | | | |
| Modification factor for cracked and uncracked concrete ⁵ | $\psi_{c,N}$ | — | 1.0 | | | 1.0 | | | |
| Strength reduction factor ϕ for tension, concrete failure modes, Condition B ⁴ | ϕ | — | 0.65 | | | 0.65 | | | |
| Data for Pullout Strengths | | | | | | | | | |
| Pullout strength, uncracked concrete | $N_{p,uncr}$ | lbf | See Footnote 7 | 6,540 | | 5,430 | 8,900 | | |
| Pullout strength, cracked concrete | $N_{p,cr}$ | lbf | See Footnote 7 | | | See Footnote 7 | | | |
| Pullout strength for seismic loads | N_{eq} | lbf | 2,345 | See Footnote 7 | | See Footnote 7 | | | |
| Strength reduction factor ϕ for tension, pullout failure modes, Condition B ⁴ | ϕ | — | 0.65 | | | 0.65 | | | |
| Additional Anchor Data | | | | | | | | | |
| Axial stiffness in service load range in uncracked concrete | β_{uncr} | lbf/in | 250,000 | | | 250,000 | | | |
| Axial stiffness in service load range in cracked concrete | β_{cr} | lbf/in | 20,000 | | | 20,000 | | | |

For SI: 1 inch = 25.4 mm, 1 in² = 645.16 mm², 1 lbf = 4.45 N, 1 psi = 0.006895 MPa, 1 lbf · 10²/in = 17,500 N/m.

¹The data in this table is intended to be used with the design provisions of ACI 318-14 Chapter 17 or ACI 318-11 Appendix D, as applicable; for anchors resisting seismic load combinations, the additional requirements of ACI 318-14 17.2.3 or ACI 318-11 D.3.3, as applicable, shall apply.

²Installation must comply with the manufacturers printed installation instructions and details.

³The ¹/₂- and ⁵/₈-inch diameter Trubolt + Wedge Anchors are ductile steel elements as defined by ACI 318-14 2.3 or ACI 318-11 D.1, as applicable.

⁴All values of ϕ apply to the load combinations of IBC Section 1605.2, ACI 318-14 Section 5.3 or ACI 318-11 Section 9.2, as applicable. If the load combinations of ACI 318-11 Appendix C are used, the appropriate value of ϕ must be determined in accordance with ACI 318-11 D.4.4.

For installations where reinforcement that complies with ACI 318-14 Chapter 17 or ACI 318-11 Appendix D, as applicable, requirements for Condition A is present, the appropriate ϕ factor must be determined in accordance with ACI 318-14 17.3.3 or ACI 318-11 D.4.3, as applicable.

⁵For all design cases $\psi_{c,N} = 1.0$. The appropriate effectiveness factor for cracked concrete (k_{cr}) or uncracked concrete (k_{uncr}) must be used.

⁶The actual diameter for the ⁵/₈-inch diameter anchor is 0.615-inch.

⁷Anchor pullout strength does not control anchor design. Determine steel and concrete capacities only.

⁸The notation in brackets is for the 2006 IBC.

TABLE 6—ITW RED HEAD STAINLESS STEEL TRUBOLT+ WEDGE ANCHOR SHEAR DESIGN INFORMATION^{1,2,3}

| CHARACTERISTIC | SYMBOL | UNITS | NOMINAL ANCHOR DIAMETER (inch) ⁵ | | | | | |
|--|------------------------|-----------------|---|-------------------------------|-------------------------------|-------------------------------|-------------------------------|-------------------------------|
| | | | ¹ / ₂ | | | ⁵ / ₈ | | |
| Anchor category | 1, 2 or 3 | — | 1 | | | 1 | | |
| Minimum effective embedment depth | h_{ef} | In. | 2 | | 3 ¹ / ₄ | | 2 ³ / ₄ | 4 ¹ / ₄ |
| Minimum concrete member thickness | h_{min} | In. | 4 | 6 | 6 | 8 | 6 | 6 ¹ / ₄ |
| Critical edge distance | c_{90} | In. | 6 | 6 | 7 ¹ / ₂ | 6 | 7 ¹ / ₂ | 6 ¹ / ₂ |
| Data for Steel Strengths - Shear | | | | | | | | |
| Minimum specified yield strength | f_y | psi | 65,000 | | | 65,000 | | |
| Minimum specified ultimate strength | f_{uta} | psi | 100,000 | | | 100,000 | | |
| Effective shear stress area (thread) | $A_{se, v} [A_{se}]^7$ | in ² | 0.142 | | | 0.217 | | |
| Steel strength in shear, uncracked or cracked concrete ⁶ | V_{sa} | lbf | 7,265 | | | 10,215 | | |
| Steel strength in shear - seismic loads | V_{eq} | lbf | 5,805 | | | 8,105 | | |
| Strength reduction factor ϕ for shear, steel failure modes ⁴ | ϕ | — | 0.65 | | | 0.65 | | |
| Data for Concrete Breakout and Concrete Pryout Strengths - Shear | | | | | | | | |
| Coefficient for pryout strength | k_{cp} | — | 1.0 | 2.0 | | 2.0 | | |
| Load-bearing length of anchor | l_a | in | 2 | 3 ¹ / ₄ | | 2 ³ / ₄ | 4 ¹ / ₄ | |
| Strength reduction factor ϕ for shear, concrete failure modes, Condition B ⁴ | ϕ | — | 0.70 | | | 0.70 | | |

For SI: 1 inch = 25.4 mm, 1 in² = 645.16 mm², 1 lbf = 4.45 N, 1 psi = 0.006895 MPa, 1 lbf · 10²/in = 17,500 N/m.

¹The data in this table is intended to be used with the design provisions of ACI 318-14 Chapter 17 or ACI 318-11 Appendix D, as applicable; for anchors resisting seismic load combinations, the additional requirements of ACI 318-14 17.2.3 or ACI 318-11 D.3.3, as applicable, shall apply.

²Installation must comply with the manufacturers printed installation instructions and details.

³The ¹/₂- and ⁵/₈-inch diameter Trubolt + Wedge Anchors are ductile steel elements as defined by ACI 318-14 2.3 or ACI 318-11 D.1, as applicable.

⁴All values of ϕ apply to the load combinations of IBC Section 1605.2, ACI 318-14 Section 5.3 or ACI 318-11 Section 9.2, as applicable. If the load combinations of ACI 318-11 Appendix C are used, the appropriate value of ϕ must be determined in accordance with ACI 318-11 D.4.4. For installations where reinforcement that complies with ACI 318-14 Chapter 17 or ACI 318-11 Appendix D, as applicable, requirements for Condition A is present, the appropriate ϕ factor must be determined in accordance with ACI 318-14 17.3.3 or ACI 318-11 D.4.3, as applicable.

⁵The actual diameter for the ⁵/₈" diameter anchor is 0.615-inch.

⁶Steel strength in shear values are based on test results per ACI 355.2, Section 9.4 and must be used for design.

⁷The notation in brackets is for the 2006 IBC.

TABLE 7—EXAMPLE ITW RED HEAD CARBON STEEL TRUBOLT+ WEDGE ANCHOR AND OVERHEAD TRUBOLT+ WEDGE ANCHOR ALLOWABLE STRESS DESIGN (ASD) VALUES FOR ILLUSTRATIVE PURPOSES^{1,2,3,4,5,6,7,8,9,10}

| ANCHOR NOTATION | ANCHOR EMBEDMENT DEPTH (inches), h_{nom} | EFFECTIVE EMBEDMENT DEPTH (inches), h_{ef} | ALLOWABLE TENSION LOAD (lbs) |
|-----------------|---|---|---------------------------------|
| $3/8$ | 2 | $1^{5/8}$ | 1,090 |
| $1/2$ | $2^{1/2}$ | 2 | 1,490 |
| | $3^{3/4}$ | $3^{1/4}$ | 2,870 |
| $5/8$ | $3^{1/4}$ | $2^{3/4}$ | 2,385 |
| | $4^{3/4}$ | $4^{1/4}$ | 3,910 |
| $3/4$ | $4^{3/8}$ | $3^{3/4}$ | 3,825 |

For SI: 1 inch = 25.4 mm, 1 lbf = 4.45 N.

Design assumptions:

- ¹Single anchor with static tension load only.
- ²Concrete determined to remain uncracked for the life of the anchorage.
- ³Load combinations are in accordance with ACI 318-14 Section 5.3 or ACI 318-11 Section 9.2, as applicable, and no seismic loading.
- ⁴30 percent dead load and 70 percent live load, controlling load combination $1.2D + 1.6L$.
- ⁵Calculation of weighted average for α : $1.2D + 1.6L = 1.2(0.3) + 1.6(0.7) = 1.48$.
- ⁶ $f'_c = 2,500$ psi (normal-weight concrete).
- ⁷ $C_{a1} = C_{a2} \geq C_{ac}$.
- ⁸ $h \geq h_{min}$.
- ⁹Values are for Condition B where supplementary reinforcement in accordance with ACI 318-14 17.3.3 or ACI 318-11 D.4.3, as applicable, is not provided.
- ¹⁰The Overhead Trubolt+ Wedge version is available in a carbon steel $3/8$ -inch-diameter only.

Illustrative Procedure to Calculate Allowable Stress Design Tension Value:

RED HEAD Carbon Steel Trubolt+ Wedge Anchor $1/2$ inch diameter using an effective embedment of $3^{1/4}$ inches, assuming the given conditions in Table 3, in accordance with ACI 318-14 Chapter 17, ACI 318-11 Appendix D and this report.

| PROCEDURE | CALCULATION |
|---|--|
| Step 1 Calculate steel strength of a single anchor in tension per ACI 318-14 17.4.1.2, ACI 318-11 D 5.1.2, Table 3 of this report | $\phi N_{sa} = \phi N_{sa}$ $= 0.75 * 8,925$ $= 6,694$ lbs steel strength |
| Step 2 Calculate concrete breakout strength of a single anchor in tension per ACI 318-14 17.4.2.1, ACI 318-11 D 5.2.1, Table 3 of this report | $N_b = k_{uncr} * \lambda_a * \sqrt{f'_c} * h_{ef}^{1.5}$ $= 24 * 1.0 * \sqrt{2,500} * 3.25^{1.5}$ $= 7,031$ lbs $\phi N_{cb} = \phi \frac{A_{NC}}{A_{NC0}} \psi_{ed,N} \psi_{c,N} \psi_{cp,N} N_b$ $= 0.65 * (95/95) / 1.0 * 1.0 * 1.0 * 7,031$ $= 0.65 * 7,031$ $= 4,570$ lbs concrete breakout strength |
| Step 3 Calculate pullout strength in tension per ACI 318-14 17.4.3.2, ACI 318-11 D 5.3.2, Table 3 of this report | $\phi N_{pn} = \phi N_{p,uncr} \psi_{c,P} (f'_{c,act} / 2,500)^D$ $= 0.65 * 6,540 * 1.0 * 1.0^{0.5}$ $= 4,251$ lbs pullout strength |
| Step 4 Determine controlling resistance strength in tension per ACI 318-14 17.3.1.1, ACI 318-11 D 4.1.1 | $= 4,251$ lbs controlling resistance |
| Step 5 Calculate allowable stress design conversion factor for loading condition per ACI 318-14 Section 5.3, ACI 318-11 Section 9.2 | $\alpha = 1.2D + 1.6L$ $= 1.2(0.3) + 1.6(0.7)$ $= 1.48$ |
| Step 6 Calculate allowable stress design value per Section 4.2 of this report | $T_{allowable,ASD} = \phi N_n / \alpha$ $= 4,251 / 1.48$ $= 2,870$ lbs allowable stress design |

TABLE 8—ITW RED HEAD CARBON STEEL TRUBOLT+ WEDGE ANCHOR AND OVERHEAD TRUBOLT+ WEDGE ANCHOR INSTALLATION INFORMATION FOR ANCHORS LOCATED IN THE SOFFIT OF CONCRETE FILL ON METAL DECK FLOOR AND ROOF ASSEMBLIES^{1,3}

| PARAMETER | SYMBOL | UNITS | NOMINAL ANCHOR DIAMETER (inch) | | | | |
|---|--------------|--------|--------------------------------|-----------------------------|-----------------------------|-----------------------------|-----------------------------|
| | | | ³ / ₈ | ¹ / ₂ | ⁵ / ₈ | | |
| Anchor outer diameter | $d_a[d_a]^2$ | inches | 0.361 | 0.5 | 0.615 | | |
| Nominal carbide bit diameter | d_{bb} | inches | ³ / ₈ | ¹ / ₂ | ⁵ / ₈ | | |
| Location of Installation | - | - | upper and lower flute | upper and lower flute | lower flute | lower flute | |
| Minimum effective embedment depth | h_{ef} | Inches | ¹ / ₂ | 2 | ³ / ₄ | ² / ₄ | ⁴ / ₄ |
| Anchor embedment depth | h_{pom} | Inches | 2 | ² / ₂ | ³ / ₄ | ³ / ₄ | ⁴ / ₄ |
| Minimum hole depth | h_o | Inches | ² / ₄ | ² / ₄ | 4 | ³ / ₂ | 5 |
| Minimum overall anchor length | l_{anchor} | Inches | ² / ₂ | ³ / ₄ | ⁴ / ₂ | ⁴ / ₄ | 6 |
| Installation torque | T_{inst} | ft-lb | 30 | 45 | | 90 | |
| Minimum diameter of hole in fastened part | d_h | inches | ¹ / ₂ | ⁵ / ₈ | | ³ / ₄ | |

For SI: 1 inch = 25.4 mm, 1 ft-lb = 1.356 N-m.

¹Anchors in the lower and upper flute may be installed with a maximum 1-inch offset in either direction from the center of the flute. In addition, anchors must have an axial spacing along the flute equal to the greater of $3h_{ef}$ or 1.5 times the flute width.

²The notation in brackets is for the 2006 IBC.

³The Overhead Trubolt+ Wedge version is available in a carbon steel ³/₈-inch-diameter only.

TABLE 9—ITW RED HEAD CARBON STEEL TRUBOLT+ WEDGE ANCHOR AND OVERHEAD TRUBOLT+ WEDGE ANCHOR DESIGN INFORMATION FOR ANCHORS LOCATED IN THE SOFFIT OF CONCRETE FILL ON METAL DECK FLOOR AND ROOF ASSEMBLIES^{1,2}

| CHARACTERISTIC | SYMBOL | UNITS | NOMINAL ANCHOR DIAMETER (inch) | | | | |
|---|----------------------------------|--------|--------------------------------|-----------------------------|-----------------------------|-----------------------------|-----------------------------|
| | | | ³ / ₈ | ¹ / ₂ | ⁵ / ₈ | | |
| Location of Installation | - | - | upper and lower flute | upper and lower flute | lower flute | lower flute | |
| Minimum effective embedment depth | h_{ef} | inches | ¹ / ₂ | 2 | ³ / ₄ | ² / ₄ | ⁴ / ₄ |
| Characteristic pullout strength, uncracked concrete over metal deck | $N_{p, deck, uncr}$ ¹ | lbf | 2,170 | 2,515 | 5,285 | 3,365 | 6,005 |
| Characteristic pullout strength, cracked concrete over metal deck | $N_{p, deck, cr}$ ¹ | lbf | 1,650 | 1,780 | 4,025 | 2,405 | 5,025 |
| Characteristic shear strength, concrete over metal deck | $V_{sa, deck}$ ¹ | lbf | 1,640 ³ | 2,200 | 3,790 | 2,890 | 6,560 |
| Reduction factor for pullout strength in tension, Condition B | ϕ | - | 0.65 | 0.65 | | 0.65 | |
| Reduction factor for steel strength in shear, Condition B | ϕ | - | 0.60 | 0.65 | | 0.65 | |

For SI: 1 inch = 25.4 mm, 1 lbf = 4.45 N.

¹Values for $N_{p, deck}$ and $V_{sa, deck}$ apply to sand-lightweight concrete having a minimum concrete compressive strength, f'_c , of 3,000 psi [minimum of 24 MPa is required under ADIBC Appendix L, Section 5.1.1].

²All values of ϕ apply to the load combinations of IBC Section 1605.2, ACI 318-14 Section 5.3 or ACI 318-11 Section 9.2. If the load combinations of ACI 318-11 Appendix C are used, the appropriate value of ϕ must be determined in accordance with ACI 318-11 D.4.4. For installations where reinforcement that complies with ACI 318-14 Chapter 17 or ACI 318-11 Appendix D, as applicable, requirements for Condition A is present, the appropriate ϕ factor must be determined in accordance with ACI 318-14 17.3.3 or ACI 318-11 D.4.3, as applicable.

³For seismic applications according to Section 4.10.3 of this report multiply the value of $V_{sa, deck}$ by 0.84.

Nominal Anchor Diameter = 3/8"

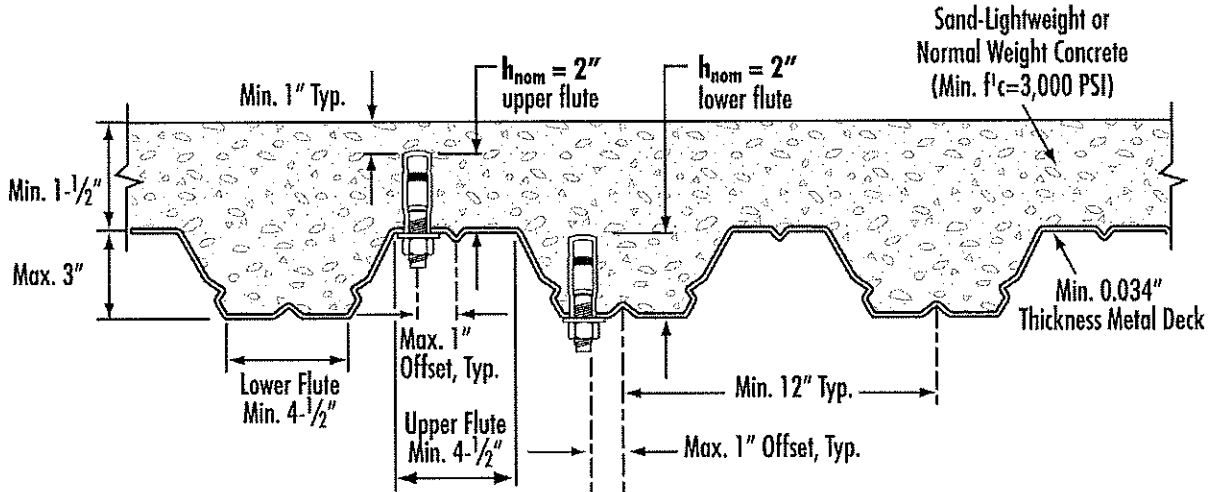

Nominal Anchor Diameter = 1/2"

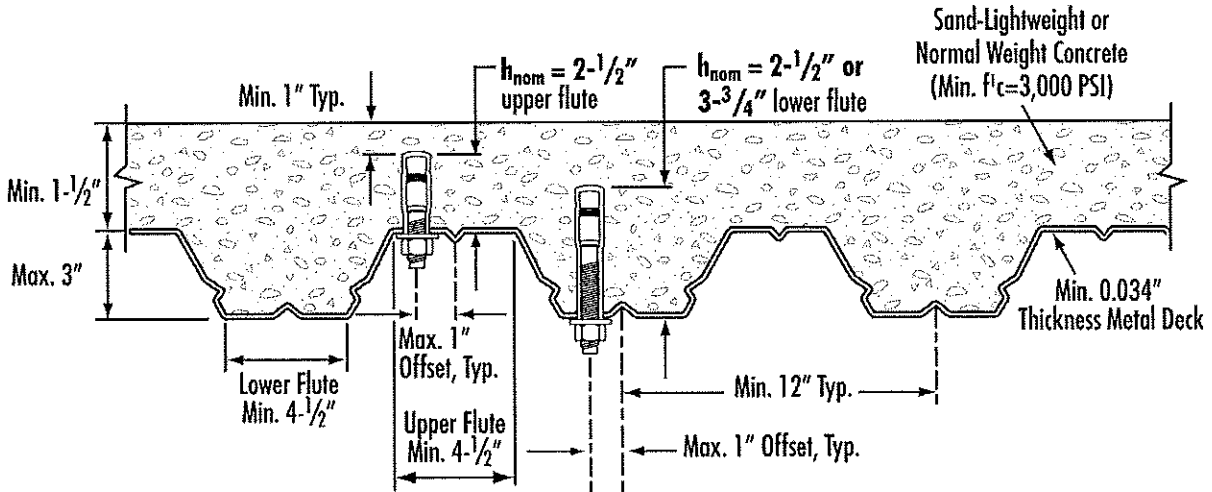

Nominal Anchor Diameter = 5/8"

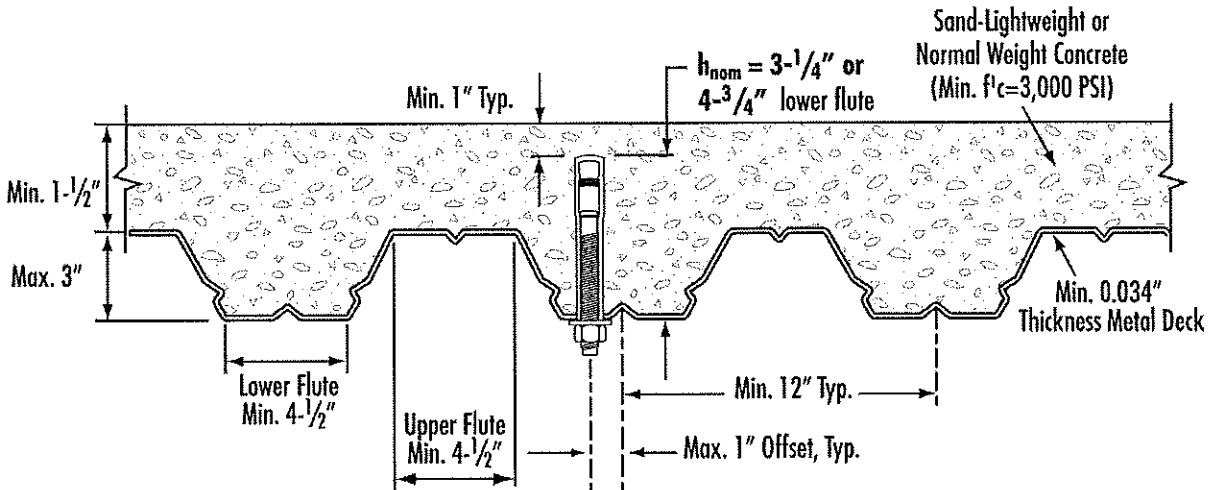

FIGURE 7—ITW RED HEAD CARBON STEEL TRUBOLT+ WEDGE ANCHOR AND OVERHEAD TRUBOLT+ WEDGE ANCHOR LOCATED IN THE SOFFIT OF CONCRETE OVER STEEL DECK FLOOR AND ROOF ASSEMBLIES (1 inch = 25.4 mm)

1029



Most Widely Accepted and Trusted

ICC-ES Evaluation Report

ESR-2427 FBC Supplement

Reissued November 2016

This report is subject to renewal November 2017.

www.icc-es.org | (800) 423-6587 | (562) 699-0543

A Subsidiary of the International Code Council®

DIVISION: 03 00 00—CONCRETE
Section: 03 16 00—Concrete Anchors

DIVISION: 05 00 00—METALS
Section: 05 05 19—Post-installed Concrete Anchors

REPORT HOLDER:

ITW RED HEAD
700 HIGH GROVE BOULEVARD
GLENDALE HEIGHTS, ILLINOIS 60139
(800) 848-5611
www.itw-redhead.com
techsupport@itwccna.com

EVALUATION SUBJECT:

ITW RED HEAD CARBON STEEL TRUBOLT+ WEDGE ANCHORS, STAINLESS STEEL TRUBOLT+ WEDGE ANCHORS AND CARBON STEEL OVERHEAD TRUBOLT+ WEDGE ANCHORS FOR CRACKED AND UNCRACKED CONCRETE

1.0 REPORT PURPOSE AND SCOPE

Purpose:

The purpose of this evaluation report supplement is to indicate that ITW Red Head Trubolt+ Wedge Anchors and OVERHEAD Trubolt+ Wedge Anchors for Cracked and Uncracked Concrete, recognized in ICC-ES master evaluation report ESR-2427, have also been evaluated for compliance with the codes noted below.

Applicable code editions:

- 2014 and 2010 *Florida Building Code—Building*
- 2014 and 2010 *Florida Building Code—Residential*

2.0 CONCLUSIONS

The ITW Red Head Trubolt+ Wedge Anchors and OVERHEAD Trubolt+ Wedge Anchors for Cracked and Uncracked Concrete, described in Sections 2.0 through 7.0 of the master evaluation report ESR-2427, comply with the 2014 and 2010 *Florida Building Code—Building* and the 2014 and 2010 *Florida Building Code—Residential*, provided the design and installation are in accordance with the 2012 *International Building Code*® provisions noted in the master report and the following provisions apply:

- Design wind loads must be based on Section 1609 of the 2014 and 2010 *Florida Building Code—Building* or Section 301.2.1.1 of the 2014 and 2010 *Florida Building Code—Residential*, as applicable.
- Load combinations must be in accordance with Section 1605.2 or Section 1605.3 of the 2014 and 2010 *Florida Building Code—Building*, as applicable.

Use of the ITW Red Head Trubolt+ Wedge Anchors and OVERHEAD Trubolt+ Wedge Anchors for Cracked and Uncracked Concrete for compliance with the High-Velocity Hurricane Zone provisions of the 2014 and 2010 *Florida Building Code—Building* and the 2014 and 2010 *Florida Building Code—Residential* has not been evaluated, and is outside the scope of this supplemental report.

For products falling under Florida Rule 9N-3, verification that the report holder's quality-assurance program is audited by a quality-assurance entity approved by the Florida Building Commission for the type of inspections being conducted is the responsibility of an approved validation entity (or the code official when the report holder does not possess an approval by the Commission).

This supplement expires concurrently with the master report, reissued November 2016.

ICC-ES Evaluation Reports are not to be construed as representing aesthetics or any other attributes not specifically addressed, nor are they to be construed as an endorsement of the subject of the report or a recommendation for its use. There is no warranty by ICC Evaluation Service, LLC, express or implied, as to any finding or other matter in this report, or as to any product covered by the report.



Table 12.2A Lag Screw Reference Withdrawal Design Values, W¹

Tabulated withdrawal design values (W) are in pounds per inch of thread penetration into side grain of wood member. Length of thread penetration in main member shall not include the length of the tapered tip (see 12.2.1.1).

| Specific Gravity, G ² | Lag Screw Diameter, D | | | | | | | | | | |
|----------------------------------|-----------------------|-------|------|-------|------|------|------|------|------|--------|--------|
| | 1/4" | 5/16" | 3/8" | 7/16" | 1/2" | 5/8" | 3/4" | 7/8" | 1" | 1-1/8" | 1-1/4" |
| 0.73 | 397 | 469 | 538 | 604 | 668 | 789 | 905 | 1016 | 1123 | 1226 | 1327 |
| 0.71 | 381 | 450 | 516 | 579 | 640 | 757 | 868 | 974 | 1077 | 1176 | 1273 |
| 0.68 | 357 | 422 | 484 | 543 | 600 | 709 | 813 | 913 | 1009 | 1103 | 1193 |
| 0.67 | 349 | 413 | 473 | 531 | 587 | 694 | 796 | 893 | 987 | 1078 | 1167 |
| 0.58 | 281 | 332 | 381 | 428 | 473 | 559 | 641 | 719 | 795 | 869 | 940 |
| 0.55 | 260 | 307 | 352 | 395 | 437 | 516 | 592 | 664 | 734 | 802 | 868 |
| 0.51 | 232 | 274 | 314 | 353 | 390 | 461 | 528 | 593 | 656 | 716 | 775 |
| 0.50 | 225 | 266 | 305 | 342 | 378 | 447 | 513 | 576 | 636 | 695 | 752 |
| 0.49 | 218 | 258 | 296 | 332 | 367 | 434 | 498 | 559 | 617 | 674 | 730 |
| 0.47 | 205 | 242 | 278 | 312 | 345 | 408 | 467 | 525 | 580 | 634 | 686 |
| 0.46 | 199 | 235 | 269 | 302 | 334 | 395 | 453 | 508 | 562 | 613 | 664 |
| 0.44 | 186 | 220 | 252 | 283 | 312 | 369 | 423 | 475 | 525 | 574 | 621 |
| 0.43 | 179 | 212 | 243 | 273 | 302 | 357 | 409 | 459 | 508 | 554 | 600 |
| 0.42 | 173 | 205 | 235 | 264 | 291 | 344 | 395 | 443 | 490 | 535 | 579 |
| 0.41 | 167 | 198 | 226 | 254 | 281 | 332 | 381 | 428 | 473 | 516 | 559 |
| 0.40 | 161 | 190 | 218 | 245 | 271 | 320 | 367 | 412 | 455 | 497 | 538 |
| 0.39 | 155 | 183 | 210 | 236 | 261 | 308 | 353 | 397 | 438 | 479 | 518 |
| 0.38 | 149 | 176 | 202 | 227 | 251 | 296 | 340 | 381 | 422 | 461 | 498 |
| 0.37 | 143 | 169 | 194 | 218 | 241 | 285 | 326 | 367 | 405 | 443 | 479 |
| 0.36 | 137 | 163 | 186 | 209 | 231 | 273 | 313 | 352 | 389 | 425 | 460 |
| 0.35 | 132 | 156 | 179 | 200 | 222 | 262 | 300 | 337 | 373 | 407 | 441 |
| 0.31 | 110 | 130 | 149 | 167 | 185 | 218 | 250 | 281 | 311 | 339 | 367 |

1. Tabulated withdrawal design values, W, for lag screw connections shall be multiplied by all applicable adjustment factors (see Table 11.3.1).
2. Specific gravity, G, shall be determined in accordance with Table 12.3.3A.

12.2.3.2 For calculation of the fastener reference withdrawal design value in pounds, the unit reference withdrawal design value in lbs/in. of fastener penetration from 12.2.3.1 shall be multiplied by the length of fastener penetration, p_f, into the wood member.

12.2.3.3 The reference withdrawal design value, in lbs/in. of penetration, for a single post-frame ring shank nail driven in the side grain of the main member, with the nail axis perpendicular to the wood fibers, shall be determined from Table 12.2D or Equation 12.2-4, within the range of specific gravities and nail diameters given in Table 12.2D. Reference withdrawal design values, W, shall be multiplied by all applicable adjustment factors (see Table 11.3.1) to obtain adjusted withdrawal design values, W¹.

$$W = 1800 G^2 D \tag{12.2-4}$$

12.2.3.4 For calculation of the fastener reference withdrawal design value in pounds, the unit reference withdrawal design value in lbs/in. of ring shank penetration from 12.2.3.3 shall be multiplied by the length of ring shank penetration, p_r, into the wood member.

12.2.3.5 Nails and spikes shall not be loaded in withdrawal from end grain of wood (C_{eg}=0.0).

12.2.3.6 Nails, and spikes shall not be loaded in withdrawal from end-grain of laminations in cross-laminated timber (C_{eg}=0.0).

12.2.4 Drift Bolts and Drift Pins

Reference withdrawal design values, W, for connections using drift bolt and drift pin connections shall be determined in accordance with 11.1.1.3.

DOWEL-TYPE FASTENERS



1031

LAG SCREWS

Table 12K LAG SCREWS: Reference Lateral Design Values, Z, for Single Shear (two member) Connections^{1,2,4,4}

for sawn lumber or SCL with ASTM A653, Grade 33 steel side plate (for $t_s < 1/4"$) or ASTM A36 steel side plate (for $t_s = 1/4"$)
(tabulated lateral design values are calculated based on an assumed length of lag screw penetration, p , into the main member equal to $8D$)

| Side Member Thickness | Lag Screw Diameter | G=0.67 Red Oak | | G=0.55 Ribbed Maple Southern Pine | | G=0.5 Douglas Fir-Larch | | G=0.49 Douglas Fir-Larch (N) | | G=0.48 Douglas Fir(S) Hem-Fir(N) | | G=0.43 Hem-Fir | | G=0.42 Spruce-Pine-Fir | | G=0.37 Redwood (open grain) | | G=0.36 Eastern Softwoods Spruce-Pine-Fir(S) Western Cedars Western Woods | | G=0.35 Northern Species | |
|-----------------------|--------------------|----------------|-------------|-----------------------------------|-------------|-------------------------|-------------|------------------------------|-------------|----------------------------------|-------------|----------------|-------------|------------------------|-------------|-----------------------------|-------------|--|-------------|-------------------------|-------------|
| | | $Z_{ }$ | Z_{\perp} | $Z_{ }$ | Z_{\perp} | $Z_{ }$ | Z_{\perp} | $Z_{ }$ | Z_{\perp} | $Z_{ }$ | Z_{\perp} | $Z_{ }$ | Z_{\perp} | $Z_{ }$ | Z_{\perp} | $Z_{ }$ | Z_{\perp} | $Z_{ }$ | Z_{\perp} | $Z_{ }$ | Z_{\perp} |
| 0.075 (14 gage) | 1/4 | 170 | 130 | 160 | 120 | 150 | 110 | 150 | 110 | 150 | 100 | 140 | 100 | 140 | 100 | 130 | 90 | 130 | 90 | 130 | 90 |
| | 5/16 | 220 | 160 | 200 | 140 | 190 | 130 | 190 | 130 | 190 | 130 | 180 | 120 | 180 | 120 | 170 | 110 | 170 | 110 | 180 | 100 |
| | 3/8 | 220 | 160 | 200 | 140 | 200 | 130 | 190 | 130 | 190 | 120 | 180 | 120 | 180 | 120 | 170 | 110 | 170 | 100 | 170 | 100 |
| 0.105 (12 gage) | 1/4 | 180 | 140 | 170 | 130 | 160 | 120 | 160 | 120 | 160 | 110 | 150 | 110 | 140 | 100 | 140 | 100 | 140 | 100 | 140 | 90 |
| | 5/16 | 230 | 170 | 210 | 150 | 200 | 140 | 200 | 140 | 190 | 130 | 190 | 130 | 190 | 120 | 180 | 110 | 170 | 110 | 170 | 110 |
| | 3/8 | 230 | 160 | 210 | 140 | 200 | 140 | 200 | 130 | 200 | 130 | 190 | 120 | 190 | 120 | 180 | 110 | 180 | 110 | 170 | 110 |
| 0.120 (11 gage) | 1/4 | 190 | 150 | 180 | 130 | 170 | 120 | 170 | 120 | 160 | 120 | 160 | 110 | 160 | 110 | 150 | 100 | 150 | 100 | 140 | 100 |
| | 5/16 | 230 | 170 | 210 | 150 | 210 | 140 | 200 | 140 | 200 | 140 | 190 | 130 | 190 | 130 | 180 | 120 | 190 | 120 | 180 | 110 |
| | 3/8 | 240 | 170 | 220 | 150 | 210 | 140 | 210 | 140 | 200 | 130 | 200 | 130 | 190 | 120 | 180 | 110 | 180 | 110 | 180 | 110 |
| 0.134 (10 gage) | 1/4 | 200 | 150 | 180 | 140 | 180 | 130 | 170 | 130 | 170 | 120 | 160 | 120 | 160 | 110 | 150 | 110 | 150 | 100 | 150 | 100 |
| | 5/16 | 240 | 180 | 220 | 160 | 210 | 150 | 210 | 140 | 200 | 140 | 200 | 130 | 200 | 130 | 190 | 120 | 180 | 120 | 180 | 120 |
| | 3/8 | 240 | 170 | 220 | 150 | 220 | 140 | 210 | 140 | 210 | 140 | 200 | 130 | 200 | 130 | 190 | 120 | 190 | 120 | 180 | 110 |
| 0.179 (7 gage) | 1/4 | 220 | 170 | 210 | 150 | 200 | 150 | 200 | 140 | 190 | 140 | 190 | 130 | 190 | 130 | 180 | 120 | 170 | 120 | 170 | 120 |
| | 5/16 | 260 | 190 | 240 | 170 | 230 | 160 | 230 | 160 | 230 | 150 | 220 | 150 | 220 | 150 | 210 | 130 | 200 | 130 | 200 | 130 |
| | 3/8 | 270 | 190 | 250 | 170 | 240 | 160 | 240 | 160 | 230 | 150 | 220 | 140 | 220 | 140 | 210 | 130 | 210 | 130 | 200 | 130 |
| 0.239 (3 gage) | 1/4 | 240 | 180 | 220 | 160 | 210 | 150 | 210 | 150 | 200 | 140 | 190 | 140 | 190 | 130 | 180 | 120 | 180 | 120 | 180 | 120 |
| | 5/16 | 300 | 220 | 280 | 190 | 270 | 180 | 260 | 180 | 260 | 170 | 250 | 160 | 250 | 160 | 230 | 150 | 230 | 150 | 230 | 140 |
| | 3/8 | 310 | 220 | 280 | 190 | 270 | 180 | 270 | 180 | 260 | 170 | 250 | 160 | 250 | 160 | 240 | 140 | 230 | 140 | 230 | 140 |
| | 7/16 | 420 | 290 | 390 | 260 | 390 | 240 | 370 | 240 | 360 | 230 | 350 | 220 | 350 | 220 | 330 | 200 | 330 | 200 | 320 | 190 |
| | 1/2 | 510 | 340 | 470 | 300 | 460 | 290 | 450 | 280 | 440 | 270 | 430 | 260 | 420 | 260 | 400 | 240 | 400 | 230 | 390 | 230 |
| | 5/8 | 770 | 490 | 710 | 430 | 680 | 400 | 680 | 400 | 660 | 380 | 640 | 370 | 630 | 360 | 600 | 330 | 590 | 330 | 580 | 320 |
| | 3/4 | 1110 | 670 | 1020 | 590 | 980 | 560 | 970 | 550 | 950 | 530 | 920 | 500 | 910 | 500 | 860 | 450 | 850 | 450 | 840 | 440 |
| | 7/8 | 1510 | 880 | 1390 | 780 | 1330 | 730 | 1320 | 710 | 1280 | 690 | 1250 | 650 | 1230 | 650 | 1170 | 590 | 1160 | 590 | 1140 | 570 |
| | 1 | 1940 | 1100 | 1760 | 920 | 1710 | 910 | 1700 | 890 | 1650 | 860 | 1600 | 820 | 1590 | 810 | 1480 | 740 | 1460 | 730 | 1450 | 710 |
| | 1/4 | 1/4 | 240 | 180 | 220 | 160 | 210 | 150 | 210 | 150 | 200 | 140 | 190 | 140 | 190 | 130 | 180 | 120 | 180 | 120 | 180 |
| 5/16 | | 310 | 220 | 280 | 200 | 270 | 180 | 270 | 180 | 260 | 170 | 250 | 170 | 250 | 160 | 230 | 150 | 230 | 150 | 230 | 140 |
| 3/8 | | 320 | 220 | 280 | 190 | 280 | 180 | 270 | 180 | 270 | 170 | 260 | 160 | 250 | 160 | 240 | 150 | 240 | 140 | 230 | 140 |
| 7/16 | | 480 | 320 | 440 | 280 | 420 | 270 | 420 | 260 | 410 | 250 | 390 | 240 | 390 | 230 | 370 | 220 | 360 | 210 | 360 | 210 |
| 1/2 | | 680 | 390 | 640 | 340 | 620 | 320 | 610 | 320 | 600 | 310 | 590 | 290 | 580 | 280 | 560 | 270 | 550 | 260 | 540 | 260 |
| 5/8 | | 850 | 530 | 780 | 470 | 750 | 440 | 740 | 440 | 720 | 420 | 700 | 400 | 690 | 400 | 660 | 370 | 650 | 360 | 640 | 350 |
| 3/4 | | 1200 | 730 | 1100 | 640 | 1060 | 600 | 1050 | 590 | 1020 | 570 | 990 | 540 | 960 | 530 | 930 | 490 | 920 | 480 | 900 | 470 |
| 7/8 | | 1600 | 930 | 1470 | 820 | 1410 | 770 | 1400 | 750 | 1360 | 720 | 1320 | 690 | 1310 | 680 | 1240 | 630 | 1220 | 620 | 1200 | 600 |
| 1 | 2040 | 1150 | 1870 | 1000 | 1800 | 950 | 1780 | 930 | 1730 | 900 | 1680 | 850 | 1660 | 840 | 1570 | 770 | 1550 | 760 | 1530 | 740 | |

1. Tabulated lateral design values, Z, shall be multiplied by all applicable adjustment factors (see Table 11.3.1).
2. Tabulated lateral design values, Z, are for "reduced body diameter" lag screws (see Appendix Table L1) inserted in side grain with screw axis perpendicular to wood fibers; screw penetration, p , into the main member equal to $8D$; dowel bearing strengths, F_{db} , of 61,850 psi for ASTM A653, Grade 33 steel and 87,000 psi for ASTM A36 steel and screw bending yield strengths, F_{yb} , of 70,000 psi for $D = 1/4"$, 60,000 psi for $D = 5/16"$, and 45,000 psi for $D \geq 3/8"$.
3. Where the lag screw penetration, p , is less than $8D$ but not less than $4D$, tabulated lateral design values, Z, shall be multiplied by $p/8D$ or lateral design values shall be calculated using the provisions of 12.3 for the reduced penetration.
4. The length of lag screw penetration, p , not including the length of the tapered tip, E (see Appendix Table L1), of the lag screw into the main member shall not be less than $4D$. See 12.1.4.6 for minimum length of penetration, p_{min} .